



Operating Manual

Tradesmig 165/235/245 & 285



**Please ensure that this
Instruction Manual is made
available to the user of
the equipment**



Contents

	Page
● Warnings	4
● Safety	5
● Introduction	7
● Installation	8
● Operation	11
● Specification	14
● Circuit Diagrams	15
● Maintenance	18
● Spare Parts	19

DECLARATION OF CONFORMITY

Murex Welding Products Ltd

Declare hereby that:

Murex Tradesmig 165, 235, 245 & 285 power sources

Part No: 1413406, 1413416, 1413421 & 1413426

From Production Serial No. 96Axxxxx

- are manufactured in accordance with the Council Directive 73/23/EEC (1973-02-19) and 89/336/EEC (1989-05-03) amended by Council Directive 93/68/EEC relating to electrical equipment designed for use within certain voltage limits.
- conform with the protection requirements of Council Directive 89/336/EEC, amended by Council Directives 91/263/EEC, 92/31/EEC and 93/68/EEC relating to electromagnetic compatibility.
- are manufactured in accordance with EN60974-1 Safety Requirements for Arc Welding Equipment
- are manufactured in accordance with EN50199 Electromagnetic Compatibility for Arc Welding Equipment.

On behalf of Murex Welding Products Ltd
Hertford Road
Waltham Cross
Herts. EN8 7RP
England



P.G. Dodd
Managing Director
Date: 1-12- 1995



WARNING



This welding equipment has been designed, manufactured and tested to the highest standards to ensure long and trouble free life. However, regular maintenance is an essential part of keeping the machine operating in a reliable and safe manner and your attention is drawn to any maintenance instructions that are contained in this manual.

In general, all welding equipment should be thoroughly inspected, tested and serviced at least annually. More frequent checking will be required when the equipment is heavily used.

Wear and tear, particularly in electro-mechanical and moving components, are gradual processes. Caught in time, repair costs are small and the benefits in performance reliability and safety are significant. Left alone, they can put the equipment, and you, at risk.

Have this equipment regularly inspected and maintained by an approved service centre.



WARNING



ARC WELDING AND CUTTING CAN BE INJURIOUS TO YOURSELF AND OTHERS. TAKE PRECAUTIONS WHEN WELDING. ASK FOR YOUR EMPLOYER'S SAFETY PRACTICES WHICH SHOULD BE BASED ON MANUFACTURERS' HAZARD DATA.

ELECTRIC SHOCK - Can Kill

- Install and earth the welding unit in accordance with applicable standards.
- Do not touch live electrical parts or electrodes with bare skin, wet gloves, or wet clothing.
- Insulate yourself from earth and work.
- Ensure your working position is secure.

FUMES AND GASES – Can be Dangerous to Health

- Keep your head out of the fumes.
- Use ventilation, extraction at the arc, or both, to keep fumes and gases from your breathing zone and the general area.

ARC RAYS – Can Injure Eyes and Burn Skin

- Protect your eyes and body. Use the correct welding screen and filter lens and wear protective clothing.
- Protect bystanders with suitable screens or curtains.

NOISE– Excessive noise can damage hearing

- Protect your ears. Use ear defenders or other hearing protection.
- Warn bystanders of the risks.

**READ AND UNDERSTAND THE INSTRUCTION MANUAL
BEFORE INSTALLING OR OPERATING AND SEE WMA PUBLICATION 237
'The arc welder at work' AVAILABLE FROM THE MANUFACTURER.**

PROTECT YOURSELF AND OTHERS

SAFETY

In any arc welding or cutting operation, it is the responsibility of the user to observe certain safety rules to ensure his personal safety and to protect those working near him.

Read all safety articles relevant to arc welding or cutting published by the WMA. Pay particular attention to any CAUTION or WARNING Notes included in this manual. CAUTION indicates possible equipment damage. WARNING indicates possible hazard to life.

⚠ WARNING ⚠

The ON/OFF switch on this equipment does not isolate the unit from the mains electrical supply. **AC POWER IS PRESENT ON THE ON/OFF SWITCH TERMINALS.**

The On/Off lamp is an indication that the supply is switched on and does not imply that the unit is isolated from the supply. **BEFORE REMOVING THE COVERS FOR MAINTENANCE, ISOLATE THE UNIT FROM THE MAINS ELECTRICAL SUPPLY.**

1. Electrical

- ⚠ Treat electricity with respect. Even the open circuit voltage of this equipment can be dangerous. Adjustments to the torch or replacement of torch parts should be undertaken with the mains supply isolated from the unit.
If damaged torch cables or torch components are found, the unit must be disconnected from the mains and defective parts must be replaced using only Murex spare parts.
- ⚠ Do not work on live circuits or cables. Disconnect the main power supply before checking the machine or performing any maintenance operation.
- ⚠ Be sure the case of the welding machine is properly connected to a good electrical earth.
- ⚠ Have the wiring for the welding machine installed by a qualified electrician. All connections must be made according to specifications in force and to general safety standards.
- ⚠ Do not stand in water or on damp floors while using an arc welder or cutter. Do not use in the rain.
- ⚠ Do not operate with worn or poorly connected cables. Inspect all cables frequently for insulation failure, exposed wires and loose connections.
- ⚠ Do not overload cables or continue to operate with overheating cables. Cables which are too small for the current carried will overheat, causing rapid deterioration of the insulation.
- ⚠ Pay attention that live parts of the torch do not touch any metal which is connected to the earth cable. Fix an insulated hook to hang the torch on when it is not in use.

1. Ventilation

- ⚠ Do not weld or cut on containers which have held combustible or flammable materials, or materials which give off flammable or toxic vapours when heated, without proper cleaning.
- ⚠ Locate the welding/cutting operation far enough from any vapour-type degreaser using trichlorethylene or other chlorinated hydrocarbons as solvents. The ultraviolet light from the arc can decompose these vapours into toxic gases at a considerable distance from the arc, even though the concentration of the gases is low enough to be undetectable by smell.
- ⚠ Be sure to provide adequate ventilation for removal and dilution of fume and gases. Fume exhaust facilities near the arc, or a ventilated helmet should be used when cutting in confined spaces or on toxic material.

2. Glare

- ⚠ Never look at the arc without wearing eye protection. Always use the proper protective clothing, filter glasses, and gloves. Be careful to avoid exposed skin areas. Do not use cracked or defective helmets or shields.
- ⚠ Never strike an arc when there is someone near who is not protected from the strong light of the arc.
- ⚠ Warn bystanders who are not aware of the dangers of ultraviolet light.

3. General

- ⚠ Take care when lifting the unit.
- ⚠ Ensure that cylinders are secured by chains.
- ⚠ Locate the unit so that there is adequate air flow to the ventilation louvres.
- ⚠ Always dress correctly to protect against glare, radiation and spatter.

4. Fire

- ⚠ Ensure that the correct type of fire extinguisher is available in the operating area.
- ⚠ Do not use near flammable materials or liquids, in or near explosive atmospheres, or on pipes carrying explosive gases.

5. Vehicle Electrics

- ⚠ When working on motor vehicles, remove the battery and any circuitry which may be damaged by the arc.
- ⚠ Whilst cutting be aware of the possibility of 'hidden wires' behind panels or bulkheads.

SAFETY - Your attention is drawn to the safety leaflets available from the Welding Institute, particularly publication 236 and 237

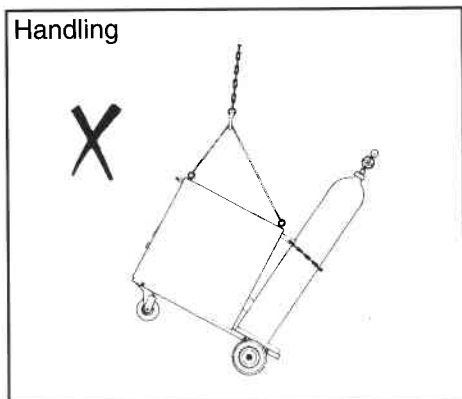

Remove cylinder before lifting

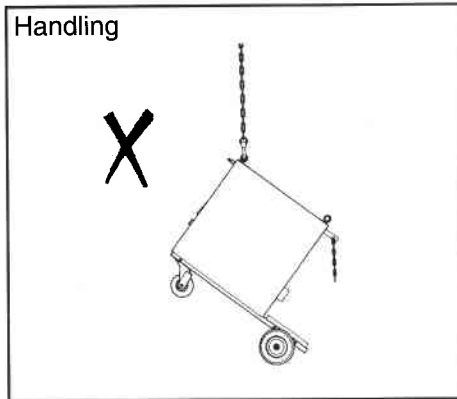

Do not lift using handle

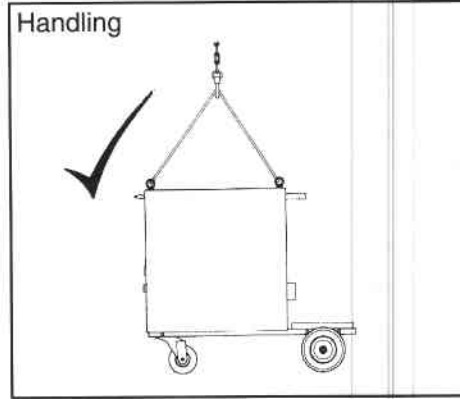

Lift the unit correctly

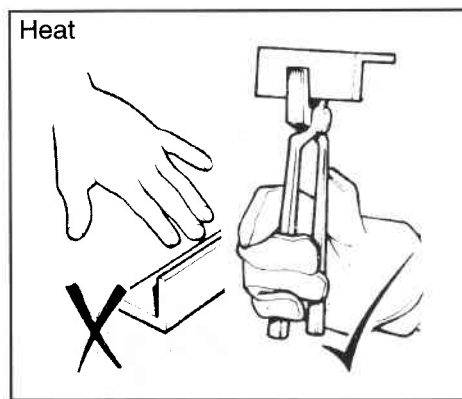

Don't burn yourself! Wear gauntlets and use tongs

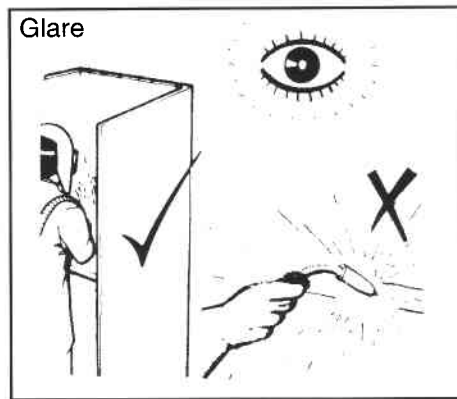

Wear your headshield (or face screen) and screen the welding area

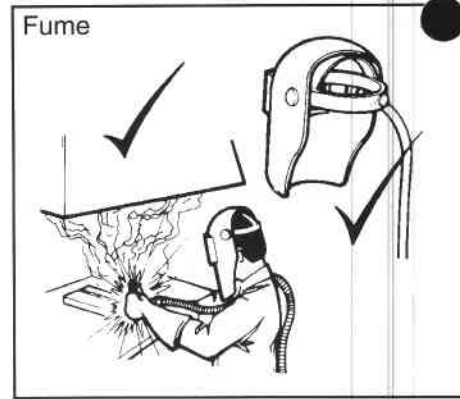

Ventilate the welding area to prevent a build-up of gas and fumes

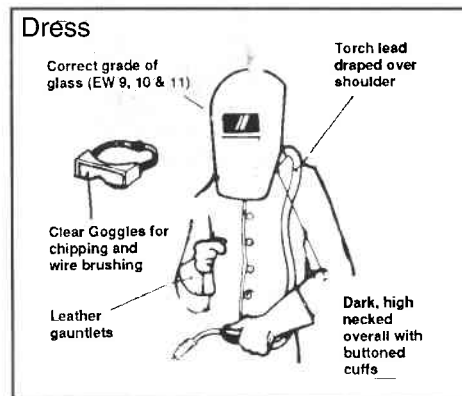

Dress correctly when welding and preparing the weld

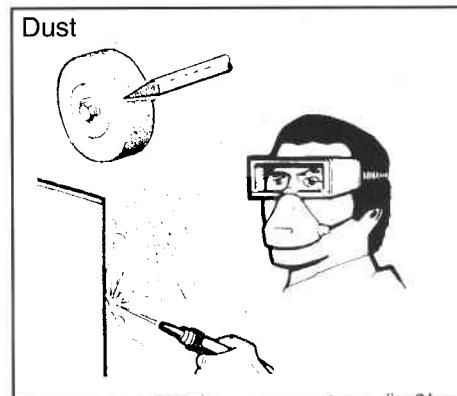

Wear goggles and mask when removing dust with an airline

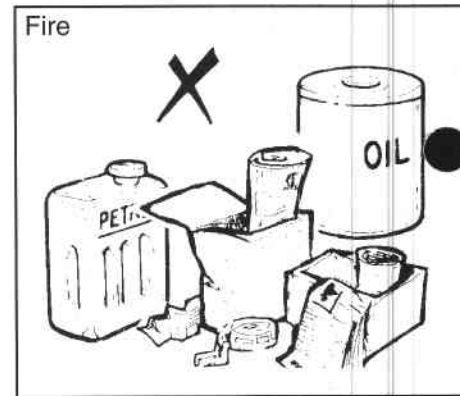

Before commencing welding, clear the area of flammable materials

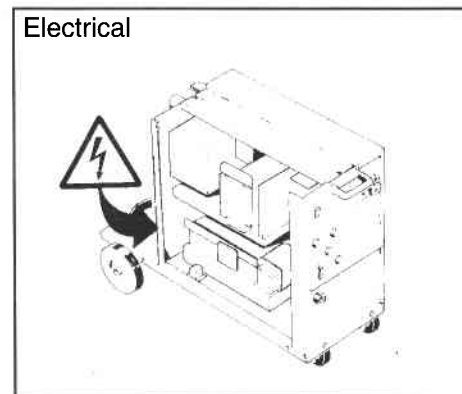

Don't work with the cover off. Leave it to the experts

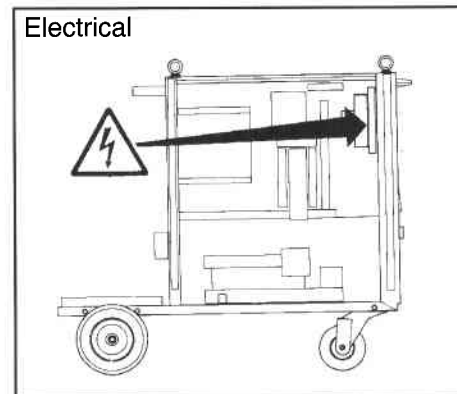

220V a.c. is supplied to the p.c.b. Isolate the unit before removing covers of p.c.b

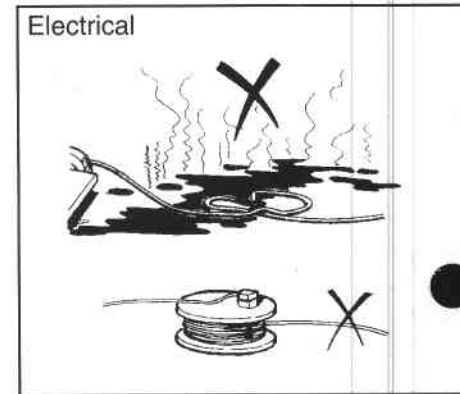

Don't allow leads to lie in oil, water or corrosive liquid, or extend them with extension leads - fit a longer cable

INTRODUCTION

The Tradesmigs 165, 235, 245 and 285 are Transformer/Rectifier MIG/MAG welding power sources fitted with an integral wire feed system. All five units are capable of continuous, spot and stitch welding using CO₂ or Argon rich gases.

A 42volt a.c. output is available to power a CO₂ heater - see page 4.

Protection against the effects of overheating is provided by thermal protection devices mounted on the transformer assembly and rectifier bridge. In the event of overheating, power to the unit is interrupted and the fault lamp is illuminated. The protective devices automatically reset once the unit cools.

NOTE

If the fault light comes on whilst welding, do not switch off but leave the unit switched on with the fan running until the protection devices reset. If the fault persists, call for technical assistance.

In the event of a mains input current surge, circuit breakers, mounted on the back panel, will interrupt a.c. supplies within the unit. These circuit breakers must be reset manually before the unit will function.

WARNING!

If the circuit breaker(s) trip and the fault lamp lights more than once or the fault lamp lights repeatedly after resetting, isolate the unit from the mains supply (remove the supply fuses) and call for technical assistance (from your Murex Service Centre Network).

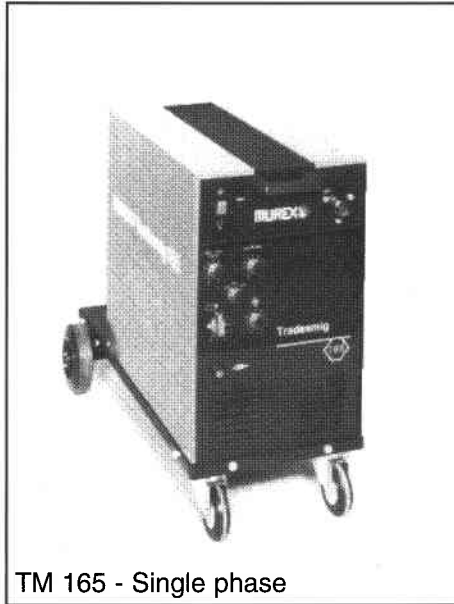

TM 165 - Single phase

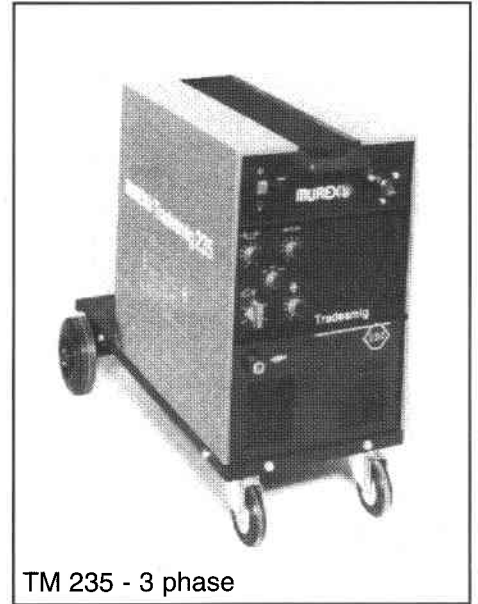

TM 235 - 3 phase

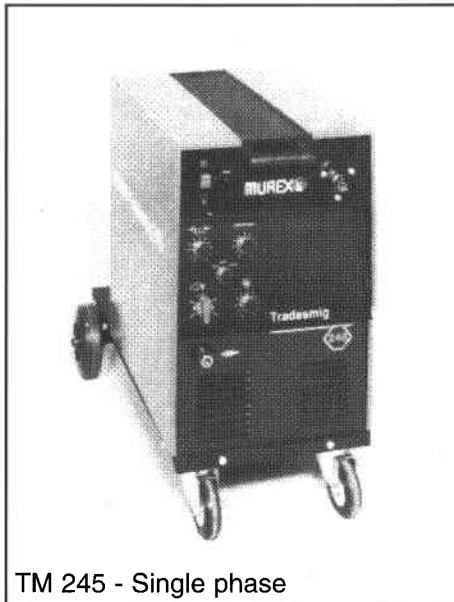

TM 245 - Single phase

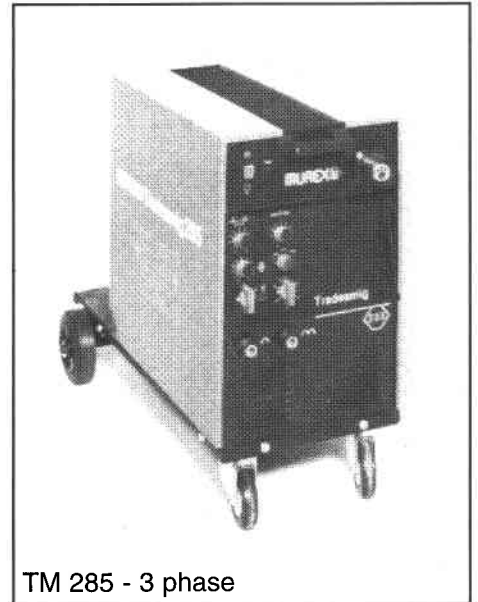

TM 285 - 3 phase

INSTALLATION

Installation must only be undertaken by a qualified electrician or suitably trained person.

Ventilation

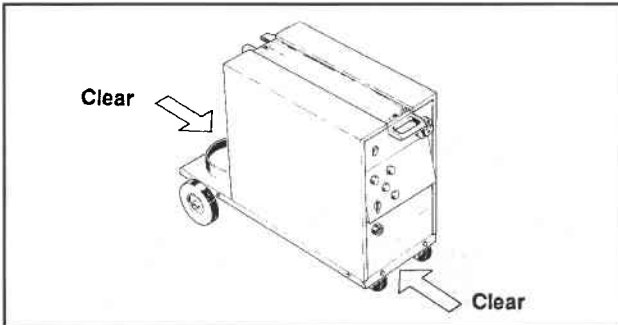

Place the unit so that the vents are clear of any obstruction to ventilating air.

Working area preparation

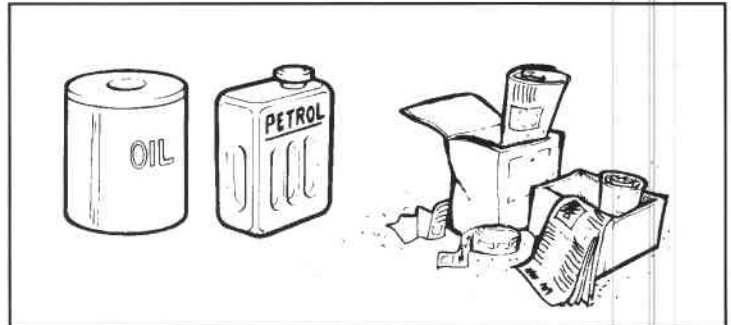

Remove all flammable materials from the area.

Electrical Connections

Remove the cover to expose the mains input selection and termination. Set the mains input selection links to suit the local mains supply voltage.

If the mains cable is not fitted, connect it to the mains input terminal block leaving sufficient slack in the earth wire.

Clamp the cable firmly.

42Vac Heater Connection TM 165, 235, 245, 285.

Feed the cable through the grommet in the back panel and connect the wires to the terminal block as shown. Clamp the cable firmly in the panel mounted clamp provided.

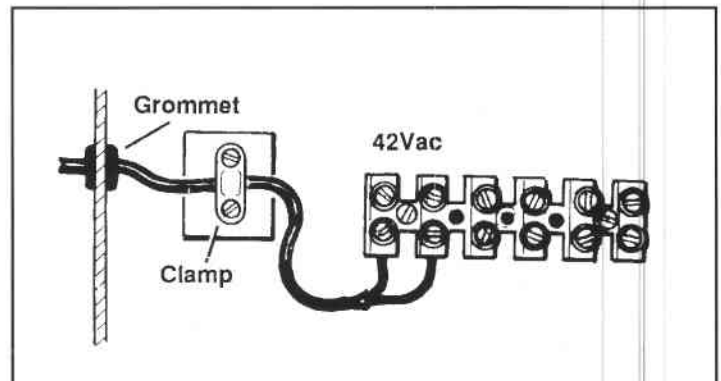

Tradesmig 235 and 285

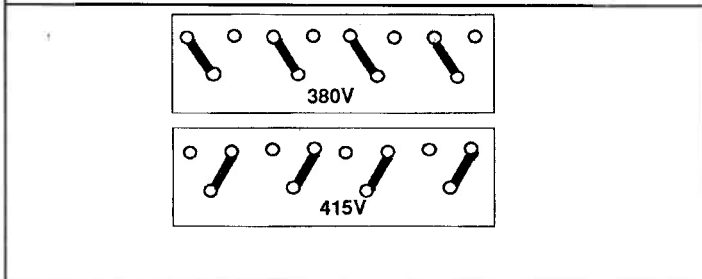
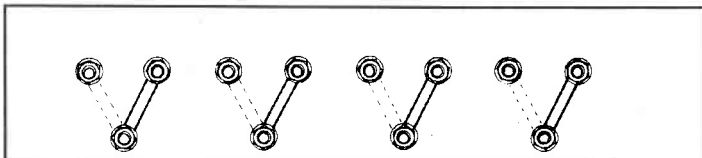
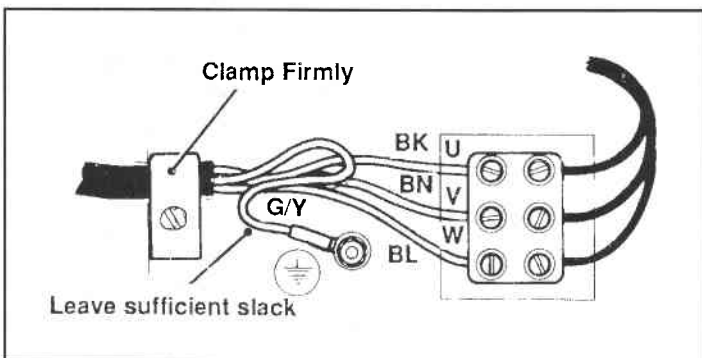

Tradesmig 165 and 245

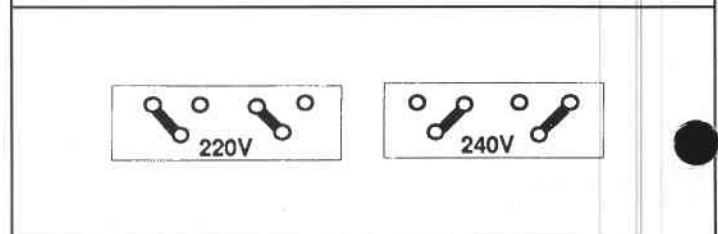
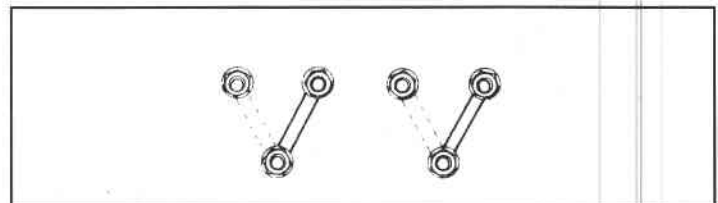
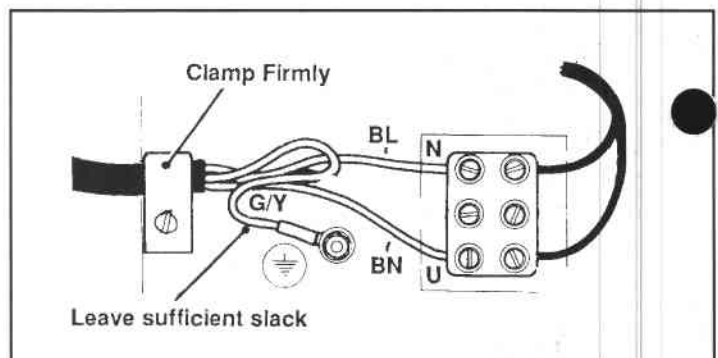

INSTALLATION

INITIAL SETTING UP

1. Check that the ON/OFF switch is 'off'.

WARNING!

This switch does not isolate the unit from the mains electrical supply.

2. **Feed Roll**

Before connecting the gas supplies, ensure that the equipment is set up for the type and size of wire to be used.

3. **Work Return Lead**

Connect the work return lead between the work return socket and a clean area on the work piece.

WELDING WIRE

Fit the reel of welding wire:

1. Remove the hand nut from the hub.
2. Place the reel of wire on the hub so that the wire will be drawn off from the top. Ensure that the pin on the hub locates in the hole in the side of the reel. Replace hub hand nut.
3. Release the end of the wire from the side of the reel but do not allow the coils to loosen. Cut off the kinked portion and remove any sharp edges from the end of the wire. This should be done every time the wire is threaded through the equipment.
4. Release the pressure roll arm.
5. Thread the wire through the inlet guide under the feed roll and into the outlet guide, for approximately 50mm (2in.).

Lock the pressure roll arm so that the welding wire is clamped into position in the groove.

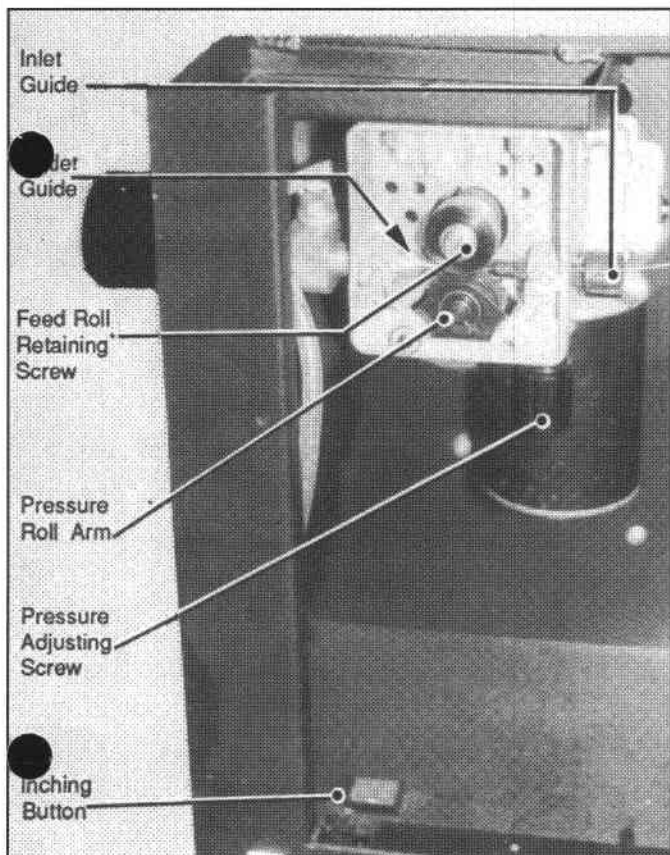

6. Switch on the power source.

7. Push the inching button and check that the wire is driven smoothly through the outlet guide.

8. Check that wire feed is smooth and positive. If the wire slips in the feed roll, tighten the pressure adjusting screw just enough to obtain positive wire feed drive.

Do not overtighten the adjusting screw.

9. Cut off the wire to protrude 10mm from the torch connector.

TORCH

1. Check that the torch lead is laid out straight and connect the torch to the torch adaptor, ensuring that the wire enters the liner correctly.

2. Remove the nozzle and contact tip from the torch. Using the inching button, feed the wire through the torch. Thread a contact tip over the wire and screw it into the torch. Tighten the contact tip with the key provided.

3. Fit the nozzle.

WARNING!

The wire, contact tip and wire feed mechanism are 'live' when the torch switch is pressed.

4. Press the torch switch and check that wire feeds smoothly from the torch.

REPLACEMENTS AND ADJUSTMENTS

1. **Guide Tube Removal**

- (a) Release the pressure roll.
- (b) If the guide tube will move freely, push it forward out of the torch adaptor using a pencil or soft wooden dowel rod, then withdraw it from the torch adaptor using a pair of long nose pliers.

If the guide tube does not move freely, it may be necessary to drive it out using a hard wooden dowel or old guide tube.

NOTE

Do not use a screwdriver or metal tool to push out the tube. Use of such a tool may damage the end of the guide and impair wire feeding.

2. **Feed Roll Changing**

Remove the feed roll retaining screw. It may be necessary to give the screwdriver a sharp twist to avoid turning the motor. Drop the pressure arm and pull off the feed roll. When replacing the feed roll, note the wire size which is stamped on the face of the roll. The required size must face outwards when the roll is refitted. Ensure that the Woodruff Key is not lost. Fit the feed roll and lock the pressure arm. Refit the retaining screw giving it a sharp twist with the screwdriver to tighten.

3. **Feed Roll Pressure**

Correct feed roll pressure will provide smooth, uninterrupted feeding of the wire. Inspection of the wire should reveal only slight marks from the feed rolls and no deformation of the wire. Use of the correct pressure is especially important when feeding aluminium wires. **The pressure should be just enough to provide positive wire drive without slipping.**

4. **Overrun adjustment**

Tighten or unscrew the hub tension nut in the centre of the wire reel hub until sufficient hub friction is achieved to prevent overrun.

NOTE

Do not overtighten or the wire will slip in the feed rolls.

INSTALLATION (continued)

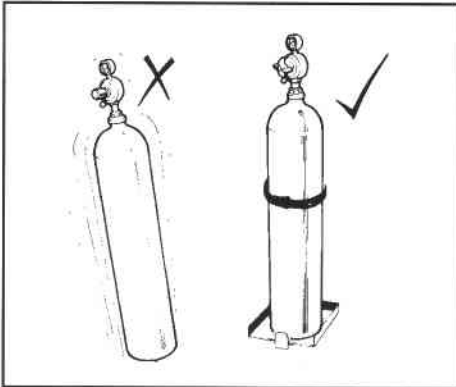

Support the gas cylinder with a retaining strap or mount it on a trolley

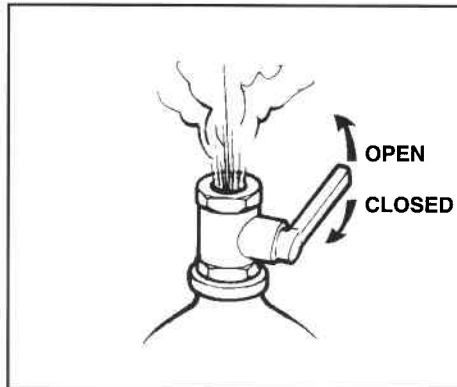

Protect the eyes and open the cylinder valve to remove any dirt in valve socket

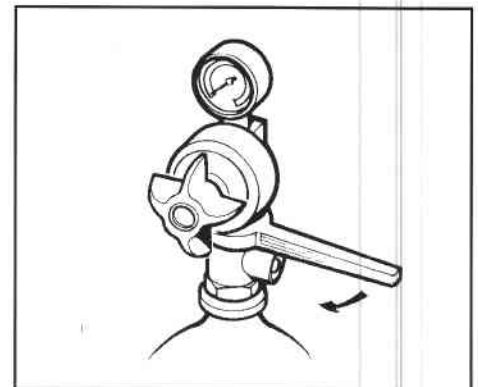

Fit the gas regulator to the cylinder and hand tighten using the correct size spanner. (A sharp blow with the hand at the end of the spanner will ensure a gas-tight seal.)

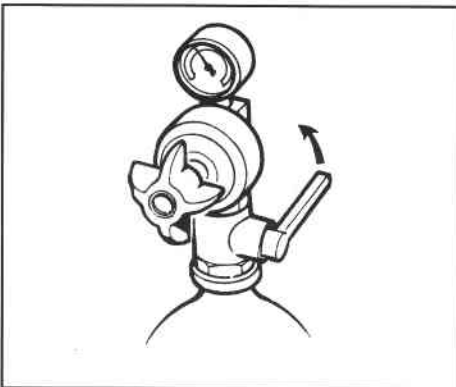

Open the cylinder valve and check the cylinder pressure. (Must be greater than 10 bar (150lb/in².)

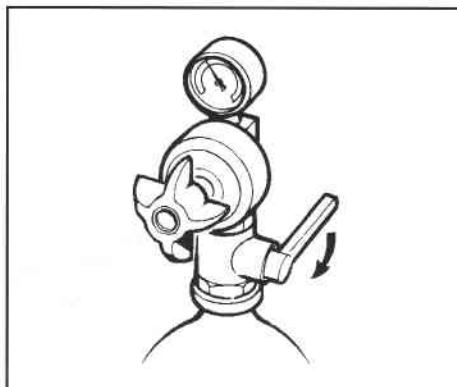

Close the cylinder valve

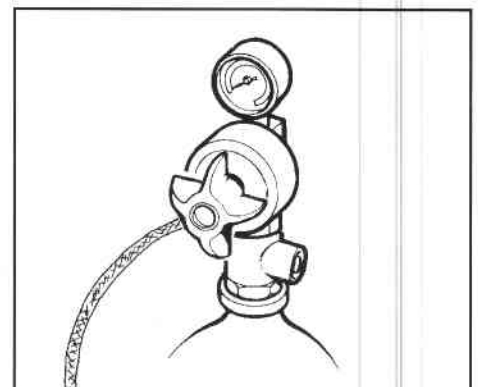

Fit the gas hose to the regulator and open cylinder valve

Clean the material to be welded with a wire brush

Clamp the work return cable to a clean area of the workpiece

Keep the gap between pieces to be welded to a minimum

Clear the welding area and check that a fire extinguisher is available

Preparation

OPERATION

ON/OFF Switch
With this switch in the ON position power is applied to the fan and control circuits.

Warning This switch does not isolate the unit from the mains electrical supply

Fault Lamp indicates unit overloaded.

Torch Connector

Inch Button (inside compartment) Operates wire feed only

t_1 - 'ON' time control for SPOT welding and STITCH 'ON' time

Wire Feed Speed (Current) Control

Mode Selection Switch Continuous / Spot / Stitch

Voltage Selector Switch - Fine

Voltage Selector Switch - Coarse (TM 285 only)

Work Return Lead Socket (TM135, 165, 235 & 245)

Inductance Socket - Low (TM 285 only)

Inductance Socket - High (TM 285 only)

Typical Controls

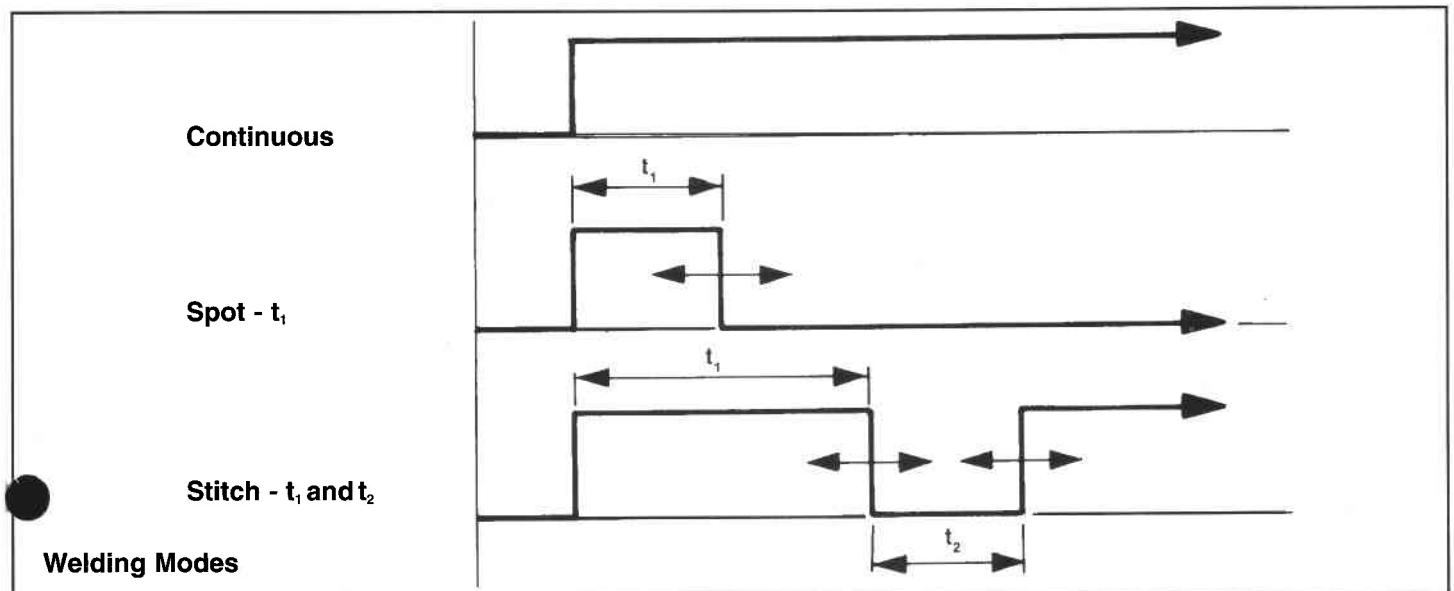

WELDING NOTES

Continuous (Bead) Welding

Produces a continuous weld whilst the torch switch is pressed.

1. Switch the process switch to the 'Continuous' welding position (left)
2. Set the voltage and wire feed controls to the appropriate positions for the material to be welded.
3. Trim the electrode wire so that approximately 3-5mm protrudes from the contact tip.

WARNING!

The wire, contact tip and wire feed mechanism are 'live' when the torch switch is pressed.

4. Position the torch over the seam to be welded as follows:
 - (a) Hold the contact tip approximately 10mm from the work surface.
 - (b) Hold the torch so that it makes an angle of approximately 70 degrees to the work surface.
 - (c) Position the torch so that the nozzle is parallel to the seam to be welded.
5. **WARN BYSTANDERS TO SHIELD THEIR EYES.**
Lower your helmet.
6. Press the torch switch to strike an arc and, as the weld is deposited, push the torch slowly along the seam at a constant speed.
7. Using the wire feed speed control, adjust for a 'crisp' sounding arc.

NOTE

Low settings of wire feed speed will cause a long drawn out arc and spattering, high settings of wire feed will cause stubbing.

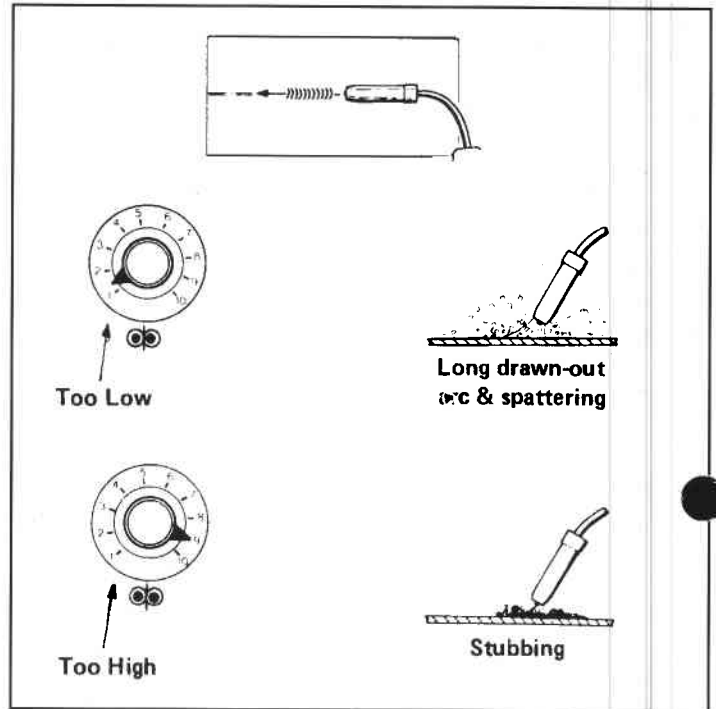

Stitch Welding

The wire feed output is switched on and off repeatedly. This produces a lower heat input which is particularly advantageous when welding thin or poor quality materials as well as bridging gaps.

1. Select 'Stitch Welding' by turning the process switch to the right-hand position.
2. Set the 't₁' and 't₂' controls to the half-way setting:
Vary the time to obtain best results.

Lower on time = Lower duration of wire feed = Lower heat input.

3. Because of increased burn-back towards the contact tip during interval welding the wire 'stick out' should be held to 6mm (not 3mm).

WARNING!

The wire, contact tip and wire feed mechanism are 'live' when the torch switch is pressed.

4. Press the torch switch and the welding process commences. When the 't₁' weld time has elapsed the wire feed stops, causing the welding process to cease. After the pause time (t₂), the wire feed re-starts. This procedure is repeated for as long as the torch trigger remains pressed.

NOTE

Low settings of wire feed speed will cause a long drawn out arc and spattering, high settings of wire feed will cause stubbing.

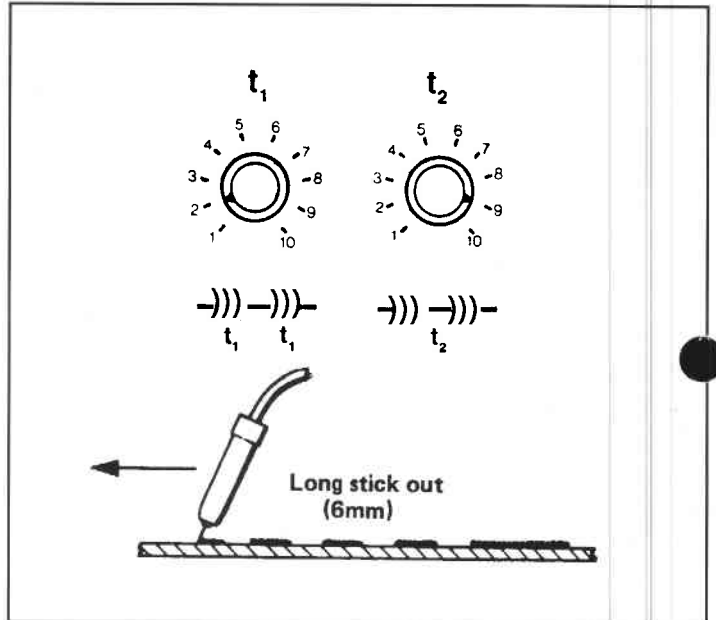

Spot Welding

A circular spot is produced each time the torch switch is pressed. The spot weld time (t₁) can be varied.

1. Select 'spot' welding by turning the process switch to the centre position.
2. Fit a spot weld nozzle to the torch.
3. Set the voltage and wire feed speed controls to near maximum setting and carry out test welds on scrap materials as follows:
4. Position the support legs of the torch nozzle over the weld area.
5. Press the torch switch and hold the torch over the weld for a few seconds after the weld is complete. Adjust the spot weld time for best results.
6. Check for good weld penetration (small dimple showing on underside of the material).

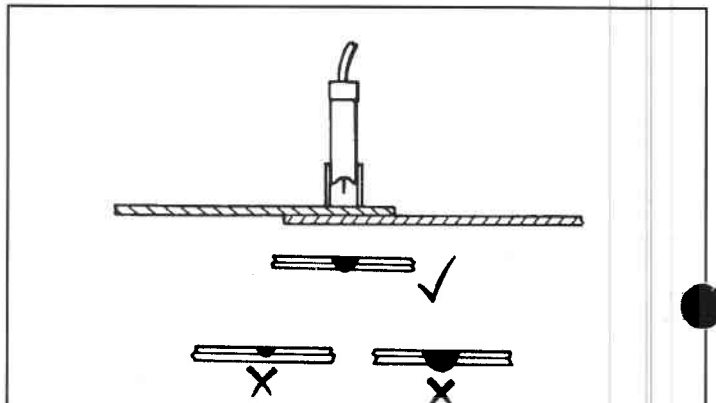

CONTINUOUS WELDING FAULTS

FAULT	POSSIBLE CAUSE AND REMEDY
1. Weld deposit 'stringy' and incomplete	1a. Torch moved over workpiece too quickly 1b. Gas mixture incorrect.
2. Weld deposit too thick	2a. Torch moved over workpiece too slowly 2b. Welding voltage too low
3. Arc unstable, excessive spatter and weld porosity	3a. Torch held too far from the workpiece 3b. Rust, grease or paint on workpiece 3c. Insufficient shielding gas, check gas contents gauge, regulator setting and operation of gas valve.
4. Wire repeatedly burns back	4a. Torch held too close to the workpiece 4b. Intermittent break in the welding circuit caused by: (1) Contact tip loose - tighten (2) Contact tip damaged - replace (3) Welding wire or liner corroded - replace wire or liner 4c. Wire feed slipping caused by: (1) Restriction in Liner (such as kinks) or contact tip - check and replace if necessary. (2) Worn feed rolls - replace (3) Outlet guide or pressure roll alignments incorrect.
5. Burning holes in the workpiece	5a. Torch moved too slowly or erratically 5b. Welding volts too high 5c. Wire feed speed too high
6. Lack of penetration	6a. Torch moved too fast 6b. Welding volts too low 6c. Wire feed speed too low

SPOT WELDING FAULTS

FAULT	POSSIBLE CAUSE AND REMEDY
1. Insufficient penetration	1a. Spot weld time too short 1b. Gap between metals to be joined too wide 1c. Wrong switch position 1d. Welding settings too low
2. Holes burnt through workpiece	2a. Spot weld time too long 2b. Gap between metals to be joined too wide 2c. Weld is too close to the edge of the material 2d. Welding settings too low
3. Wire sticks to contact tip or workpiece at the end of the weld	3a. Burn-off time incorrect - expert assistance required since burn-back must be accurately timed.
4. Wire burns back	4a. Poor gas coverage 4b. Burn-back time incorrect (see 3 above)

Tradesmig 165/235/245/285

Technical Notes

SPECIFICATION

	TM165	TM235	TM245	TM285
Input				
Nominal Voltage	220/240V	380/415V	220/240V	380/415V
Phase	1	3	1	3
Frequency	50/60Hz	50/60Hz	50/60Hz	50/60Hz
Max. KVA	4	9	8	15
Fuse rating at supply voltage	16A	20A	30A	25A
Output				
Open circuit voltage	18 - 32V	20 - 30V	22 - 36V	18 - 44V
Welding range	30 - 160A	40 - 230A	60 - 240A	40 - 300A
Rated output				
100% duty cycle	60A	110A	90A	120A
60% duty cycle	70A	140A	110A	150A
35% duty cycle		180A		
20% duty cycle	125A		200A	270A
Control	8 position switched	6 position switched	6 position switched	2x6 position switched
Rating specification	EN60-974	EN60-974	EN60-97H	EN60-974
Max ambient temp	40 deg. C	40 deg. C	40 deg. C	40 deg. C
Insulation class	F and H	F and H	F and H	F
Spot weld timer	0.5 to 2 Sec.	0.5 to 2 Sec.	0.5 to 2 Sec.	0.5 to 2 Sec.
Stitch weld timer	0.5 to 2 Sec.	0.5 to 2 Sec.	0.5 to 2 Sec.	0.5 to 2 Sec.
Dimensions				
Height (with wheels)	710mm	710mm	710mm	710mm
Width (with wheels)	500mm	500mm	500mm	500mm
Depth (overall)	890mm	890mm	890mm	390mm
Weight (Nett)				
	63Kg	75Kg	80Kg	96Kg

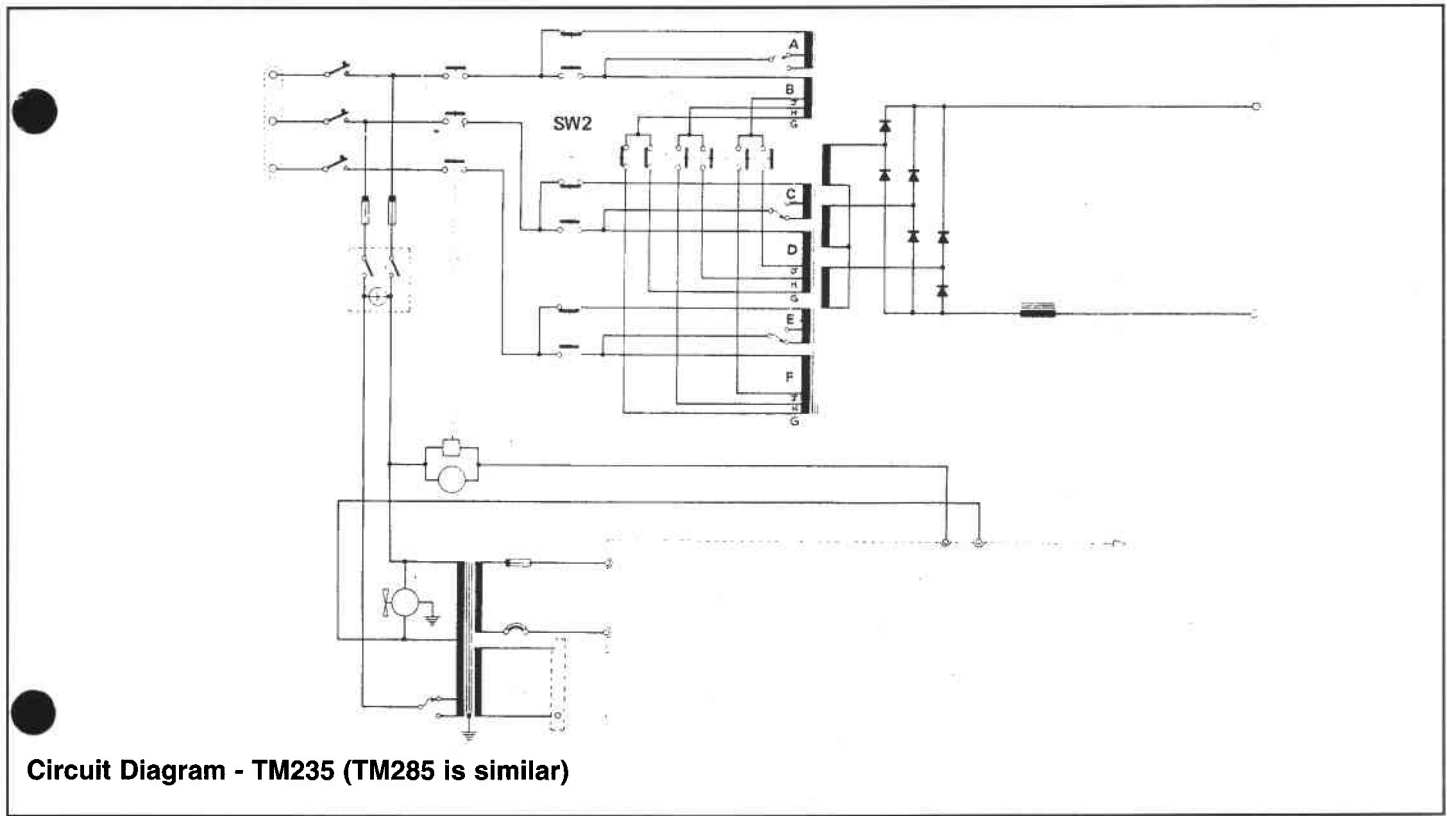
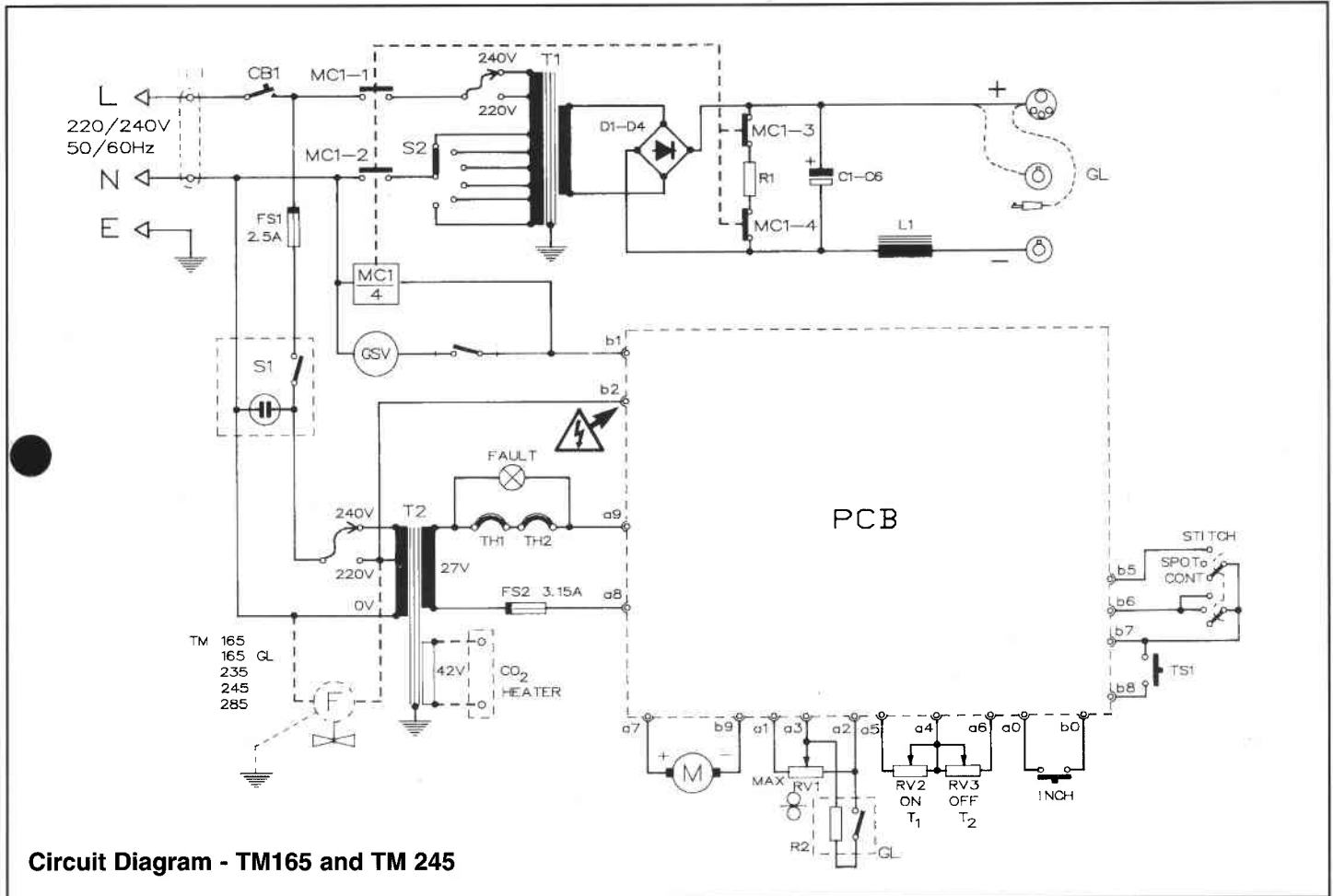

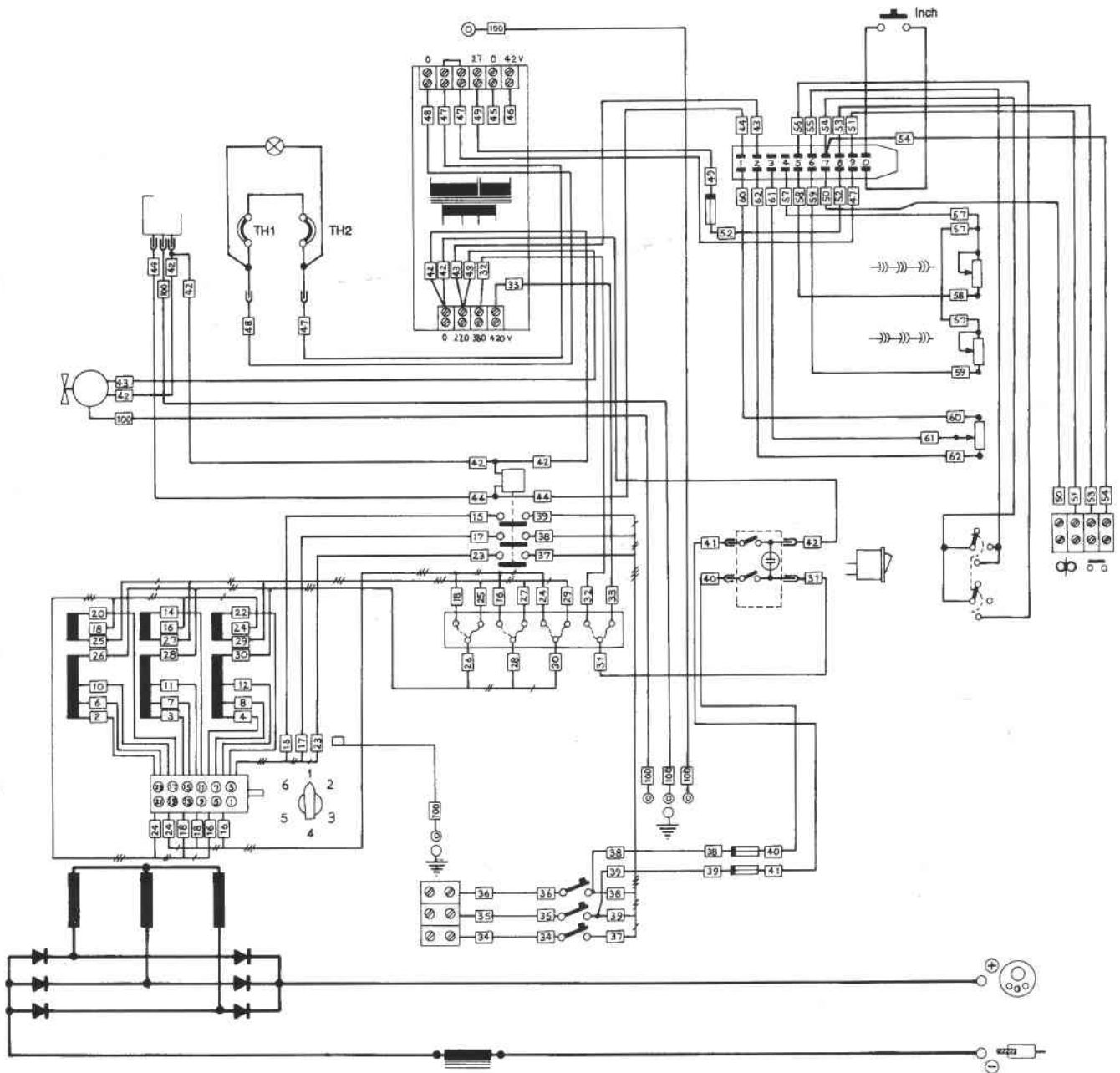

THREE PHASE WIRING - TYPICAL

ROUTINE MAINTENANCE

The following maintenance procedure should be carried out **at least twice a year**.

1. Isolate unit from the mains supply. Remove the side panels. Carefully brush away any dust which is found on the electrical parts. (If an air line is used to blow the dust off, be careful that the air jet does not force the dust into the electrical parts. Also be careful not to cause dust clouds which might harm personnel.)

WARNING!

When using an airline to remove dust, use only DRY AIR at a pressure not exceeding 2 bar, and wear a mask and goggles.

2. Check all the electrical and mechanical connections to ensure that they are tight.

3. Check connections between metal parts and earth stud.

Reconnect mains supply (be careful not to touch exposed 'live' parts).

4. Check that the contactor operates properly.

5. Check the operation of all controls. Replace the covers.

6. Check the torch at least once a day to ensure that the contact tip, nozzle and insulator are clean and in proper working order.

7. Whenever a new coil of wire has to be used, blow out the torch wire feed liner with an air line. See 'Warning'.

8. **Check each day** to see that the drive roll pressure is correct.

9. **Once each week** clean dirt and metal dust from around the drive rolls, and check that the drive roll is not excessively worn.

CAUTION

When cleaning inside the wire feed unit, be careful not to force metal dust into the electrical components as this may cause a short circuit fault to occur.

10. **At least once a month** check all connections to see that they are tight, check insulators and grommets for wear.

INSULATION AND CONTINUITY TESTS

These tests should be carried out before installation and after periods of non use.

Before carrying out these tests, ensure that the unit is isolated from the electrical mains supply.

Preparation

1. Join together the live and neutral wires which are connected to TB1.
2. Connect together the welding output SK1 and work return socket SK2.
3. Ensure that circuit breakers CB1 (TM 135, 165, 165GL & 245) or CB1, 2 and 3 (TM 235 & 285) on the back panel are closed.
4. Close the On/Off switch S1.
5. Remove the pcb completely.
6. Disconnect the earth lead from the fan F.
7. Close the main contactor MCI/4.

Continuity

Using an ohm meter of 10,000 ohms per volt or better (e.g. AVO) check for continuity between the mains input cable earth wire and chassis earth points - see wiring diagrams.

Insulation Tests

With an insulation tester (e.g. Megger), check for readings greater than 100K ohms between:

- (a) The mains input wires and output terminals
- (b) The mains input wires and A8 (fuse 2) on the pcb socket.
- (c) The mains input wires and the earth wire.