

GB

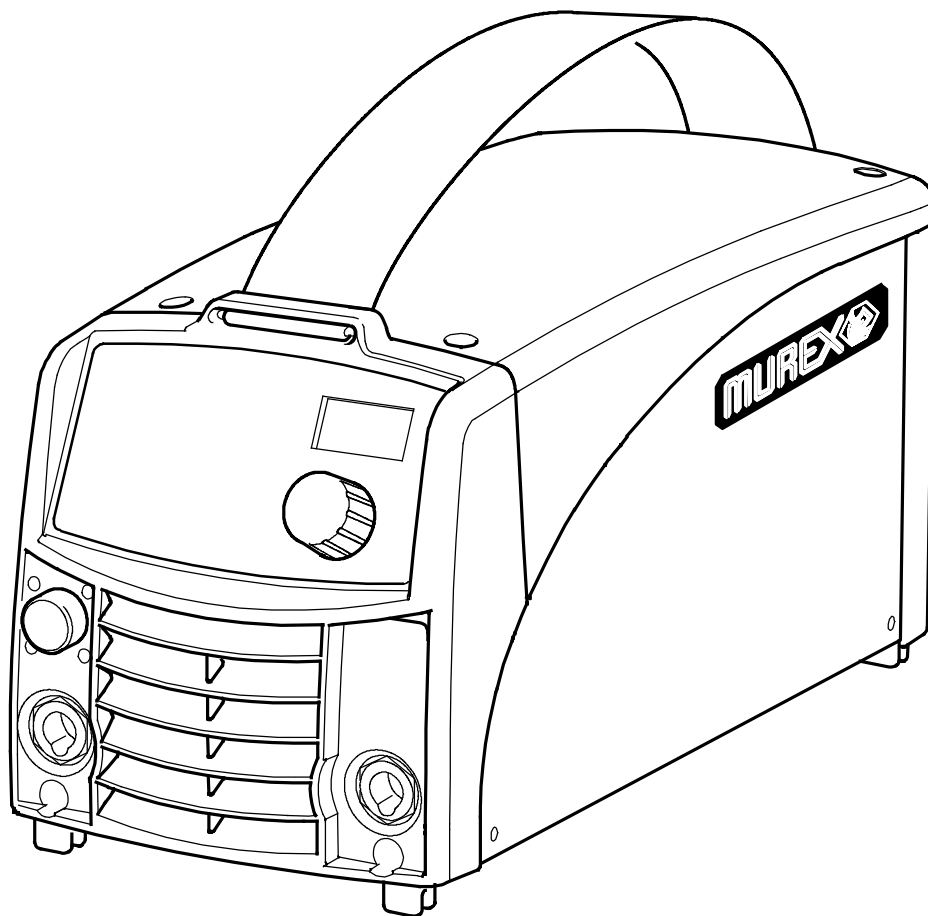

# *Tradesarc 200*



Instruction manual and  
spare parts list

<b>1 DIRECTIVE</b>	<b>3</b>
<b>2 SAFETY</b>	<b>3</b>
<b>3 INTRODUCTION</b>	<b>4</b>
3.1 Equipment	5
3.2 Control panel	5
<b>4 TECHNICAL DATA</b>	<b>5</b>
<b>5 INSTALLATION</b>	<b>6</b>
5.1 Location	6
5.2 Mains power supply	6
<b>6 OPERATION</b>	<b>7</b>
6.1 PFC – Power factor correction	7
6.2 Connections and control devices	7
6.3 Connection of welding and return cable	7
6.4 Overheating protection	7
6.5 MMA welding	8
6.6 TIG welding	8
6.7 Remote control unit	9
<b>7 MAINTENANCE</b>	<b>9</b>
7.1 Inspection and cleaning	9
<b>8 FAULT-TRACING</b>	<b>10</b>
8.1 Fault codes	10
<b>9 CONTROL PANEL</b>	<b>10</b>
<b>10 MMA WELDING</b>	<b>12</b>
10.1 Settings	12
10.2 Symbol and Function explanations	12
10.3 Hidden functions MMA welding	13
<b>11 TIG WELDING</b>	<b>13</b>
11.1 Settings	13
11.2 Symbol and Function explanations	14
<b>12 WELDING DATA MEMORY</b>	<b>14</b>
<b>13 FAULT CODES</b>	<b>15</b>
13.1 Fault code descriptions	15
<b>14 ORDERING SPARE PARTS</b>	<b>16</b>
<b>15 DISMANTLING AND SCRAPPING</b>	<b>16</b>
<b>DIAGRAM</b>	<b>18</b>
<b>SPARE PARTS LIST</b>	<b>21</b>
<b>ACCESSORIES</b>	<b>26</b>

---

# 1 DIRECTIVE

---

## DECLARATION OF CONFORMITY

Murex Welding Products Ltd, EN8 7TF England, gives its unreserved guarantee that welding power source Tradesarc 200 from serial number 827 (2008 w 27) are constructed and tested in compliance with the standard EN 60974-1 and EN 60974-10 (Class A) in accordance with the requirements of directive (2006/95/EC) and (2004/108/EEC).

-----

On behalf of Murex Welding Products Ltd.  
Laxå 2008-08-28

Kent Eimbrodt  
Global Director  
Equipment and Automation

Manufactured by ESAB AB, Welding Equipment  
SE-695 81 Laxå Sweden

---

# 2 SAFETY

---

Users of welding equipment have the ultimate responsibility for ensuring that anyone who works on or near the equipment observes all the relevant safety precautions. Safety precautions must meet the requirements that apply to this type of welding equipment. The following recommendations should be observed in addition to the standard regulations that apply to the workplace.

All work must be carried out by trained personnel well-acquainted with the operation of the welding equipment. Incorrect operation of the equipment may lead to hazardous situations which can result in injury to the operator and damage to the equipment.

1. Anyone who uses the welding equipment must be familiar with:
  - S its operation
  - S location of emergency stops
  - S its function
  - S relevant safety precautions
  - S welding
2. The operator must ensure that:
  - S no unauthorized person is stationed within the working area of the equipment when it is started up.
  - S no-one is unprotected when the arc is struck
3. The workplace must:
  - S be suitable for the purpose
  - S be free from drafts
4. Personal safety equipment
  - S Always wear recommended personal safety equipment, such as safety glasses, flame-proof clothing, safety gloves.
  - S Do not wear loose-fitting items, such as scarves, bracelets, rings, etc., which could become trapped or cause burns.
5. General precautions
  - S Make sure the return cable is connected securely.
  - S Work on high voltage equipment **may only be carried out by a qualified electrician.**
  - S Appropriate fire extinguishing equipment must be clearly marked and close at hand.
  - S Lubrication and maintenance must **not** be carried out on the equipment during operation.



### CAUTION!

*This product is solely intended for arc welding.*



## WARNING



*Arc welding and cutting can be injurious to yourself and others. Take precautions when welding. Ask for your employer's safety practices which should be based on manufacturers' hazard data.*

**ELECTRIC SHOCK - Can kill**

- S Install and earth the welding unit in accordance with applicable standards.
- S Do not touch live electrical parts or electrodes with bare skin, wet gloves or wet clothing.
- S Insulate yourself from earth and the workpiece.
- S Ensure your working stance is safe.

**FUMES AND GASES - Can be dangerous to health**

- S Keep your head out of the fumes.
- S Use ventilation, extraction at the arc, or both, to take fumes and gases away from your breathing zone and the general area.

**ARC RAYS - Can injure eyes and burn skin.**

- S Protect your eyes and body. Use the correct welding screen and filter lens and wear protective clothing.
- S Protect bystanders with suitable screens or curtains.

**FIRE HAZARD**

- S Sparks (spatter) can cause fire. Make sure therefore that there are no inflammable materials nearby.

**NOISE - Excessive noise can damage hearing**

- S Protect your ears. Use earmuffs or other hearing protection.
- S Warn bystanders of the risk.

**MALFUNCTION - Call for expert assistance in the event of malfunction.**

Read and understand the instruction manual before installing or operating.

**PROTECT YOURSELF AND OTHERS!**

Murex can provide you with all necessary welding protection and accessories.



**WARNING!**

*Do not use the power source for thawing frozen pipes.*



**CAUTION!**

*Read and understand the instruction manual before installing or operating.*

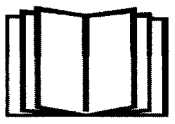

**CAUTION!**

*Class A equipment is not intended for use in residential locations where the electrical power is provided by the public low-voltage supply system. There may be potential difficulties in ensuring electromagnetic compatibility of class A equipment in those locations, due to conducted as well as radiated disturbances.*



### 3 INTRODUCTION

Tradesarc 200 is a welding current power source intended for use with coated electrodes (MMA welding) and TIG welding.

Accessories for the product can be found on page [26](#).

### 3.1 Equipment

Tradesarc 200 is supplied with a 3 m welding cable, return cable, 3 m mains cable and an instruction manual for power source and control panel.

### 3.2 Control panel

Welding process parameters are controlled via the control panel, see page 10.

---

## 4 TECHNICAL DATA

---

Tradesarc 200	
<b>Mains voltage</b>	230 V, 1 ~ 50/60 Hz
<b>Primary current</b>	
I <sub>max</sub> TIG	24 A
I <sub>max</sub> MMA	25 A
<b>Mains supply</b>	Z <sub>max</sub> 0.31 ohm
<b>No-load power demand when in the energy-saving mode, 6.5 min. after welding</b>	30 W
<b>Voltage/current range, MMA</b>	4 A /20 V - 170 A /26.8 V
<b>Voltage/current range TIG</b>	3 - 220 A
<b>Permissible load at MMA</b>	
25% duty cycle	170 A / 26.8 V
60% duty cycle	130 A / 25.2 V
100% duty cycle	110 A / 24.4 V
<b>Permissible load at TIG</b>	
20% duty cycle	220 A / 18.8 V
60% duty cycle	150 A / 16.0 V
100% duty cycle	110 A / 14.4 V
<b>Power factor at maximum current</b>	
TIG	0.99
MMA	0.99
<b>Efficiency at maximum current</b>	
TIG	75%
MMA	81%
<b>Open-circuit voltage MMA / TIG</b>	
without VRD	55 - 60 V
with VRD	< 35 V
<b>Operating temperature</b>	-10°C - +40° C
<b>Transportation temperature</b>	-20°C - +55° C
<b>Constant A-weighted sound pressure</b>	< 70 dB
<b>Dimensions, l x b x h</b>	418 x 188 x 208 mm
<b>Weight</b>	8.3 kg
<b>Enclosure class</b>	IP 23
<b>Application class</b>	S

#### Duty cycle

The duty cycle refers to the time as a percentage of a ten-minute period that you can weld at a certain load without overloading. The duty cycle is valid for 40°C.

The duty cycle is valid for 40°C.

#### Enclosure class

The IP code indicates the enclosure class, i. e. the degree of protection against penetration by solid objects or water. Equipment marked **IP23** is designed for indoor and outdoor use.

**Application class**

The symbol **S** indicates that the power source is designed for use in areas with increased electrical hazard.

**Mains supply,  $Z_{max}$**

Maximum permissible line impedance of the network in accordance with IEC 61000-3-11.

## 5 INSTALLATION

*The installation must be executed by a professional.*

**Note!**

**Mains supply requirements**

High power equipment may, due to the primary current drawn from the mains supply, influence the power quality of the grid. Therefore connection restrictions or requirements regarding the maximum permissible mains impedance or the required minimum supply capacity at the interface point to the public grid may apply for some types of equipment (see technical data). In this case it is the responsibility of the installer or user of the equipment to ensure, by consultation with the distribution network operator if necessary, that the equipment may be connected.

### 5.1 Location

Position the power source such that its cooling air inlets and outlets are not obstructed.

### 5.2 Mains power supply

Check that the welding power source is connected to the correct voltage and that the correct fuse size is used. A protective earth connection must be made in accordance with regulations

*Location of rating plate*

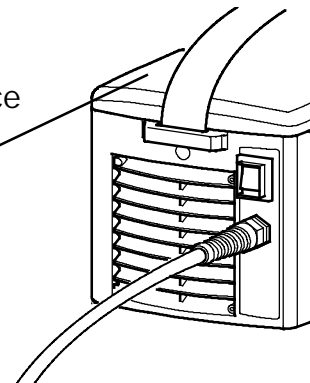

#### 5.2.1 Recommended fuse sizes and minimum cable area

Tradesarc 200	
Mains voltage	230 V $\pm$ 10 %, 1-phase
Mains frequency	50-60 Hz
Mains cable, area	3G2.5 mm <sup>2</sup>
Phase current $I_{1eff}$	14 A
Welding cable, area	16 mm <sup>2</sup>
Fuse	
anti-surge	16 A
type C MCB	16 A

**NOTE!**

The cable area and fuse rating above comply with Swedish regulations. Use the welding power source in accordance with the relevant national regulations.

## 6 OPERATION

### 6.1 PFC - Power factor correction

The Tradesarc 200 is 230 V single-phase power sources equipped with a PFC circuit making it possible to use the full range of the machine on a 16 A fuse. The PFC also protects the machines against fluctuating mains voltage and makes it safer to use with a generator. Tradesarc 200 can operate with extra long mains cables, over 100 m, giving you a very larger working radius.

### 6.2 Connections and control devices

- |  |  |
|--|--|
| <p>1 Connection (+)<br/>MMA: for return cable or welding cable<br/>TIG: for return cable</p> <p>2 Connection for remote control unit</p> <p>3 Control panel, see under 3.2</p> | <p>4 Connection (-)<br/>MMA: for return cable or welding cable<br/>TIG: for Tig torch I</p> <p>5 Toggle switch for mains power supply 0 / 1</p> <p>6 Mains cable</p> |
|--|--|

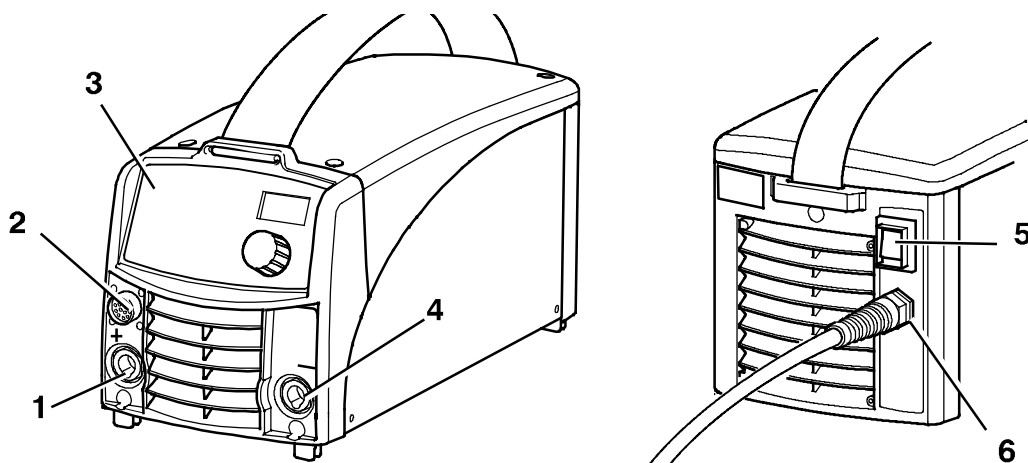

### 6.3 Connection of welding and return cable

The power source has two outputs, a positive terminal (+) and a negative terminal (-), for connecting welding and return cables. The output to which the welding cable is connected depends on the type of electrode used. The connecting polarity is stated on the electrode packaging. Connect the welding cable to the terminal stated on the electrode packaging.

Connect the return cable to the other output on the power source. Secure the return cable's contact clamp to the work piece and ensure that there is good contact between the work piece and the output for the return cable on the power source.

### 6.4 Overheating protection

The welding power source has a thermal overload trip which operates if the temperature becomes too high, interrupting the welding current and lighting a yellow indicating lamp on the front of the power source. The thermal overload trip resets automatically when the temperature has fallen.

## 6.5 MMA welding

**Tradesarc 200** gives direct current, and you can weld most metals to alloy and non-alloy steel, stainless steel and cast iron.

Tradesarc 200 allows you to weld most coated electrodes from Ø 1.6 to Ø 3.25.

MMA welding may also be referred to as welding with coated electrodes. Striking the arc melts the electrode, and its coating forms protective slag.

If, when striking the arc, the tip of the electrode is pressed against the metal, it immediately melts and sticks to the metal, rendering continued welding impossible.

Therefore, the arc has to be struck in the same way that you would light a match.

Quickly strike the electrode against the metal, then raise it so as to give an appropriate arc length (approx. 2 mm). If the arc is too long, it will crackle and spit before finally going out completely.

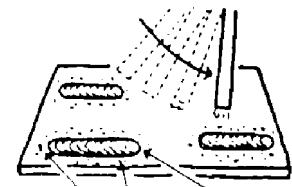

cmha2p11

If you are working on a welding bench, check before attempting to strike the arc that residual waste metal, pieces of electrode or other objects on the bench do not insulate the part to be welded.

Once the arc has been struck, move the electrode from left to right. The electrode must be at an angle of 60° to the metal in relation to the direction of welding.

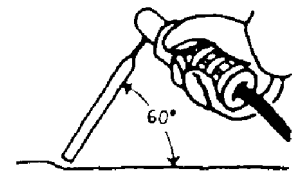

cmha2p10

When you want to weld wide beads, or when you want the weld to be so thick that you have to weld in a number of layers, however, you have to use lateral movements.

## 6.6 TIG welding

TIG welding melts the metal of the workpiece, using an arc struck from a tungsten electrode, which does not itself melt. The weld pool and the electrode are protected by shielding gas.

TIG welding is particularly useful where high quality is demanded and for welding thin plate. Tradesarc 200 also has good characteristics for TIG welding.

In order to TIG weld Tradesarc 200 must be equipped with:

- S a TIG torch with gas valve
- S a welding gas cylinder (a suitable welding gas)
- S a welding gas regulator (suitable gas regulator)
- S tungsten electrode
- S suitable auxiliary material, if necessary.

### "Live TIG-start"

With "Live TIG start" the arc strikes when the tungsten electrode is brought into contact with the workpiece and then lifted away from it.

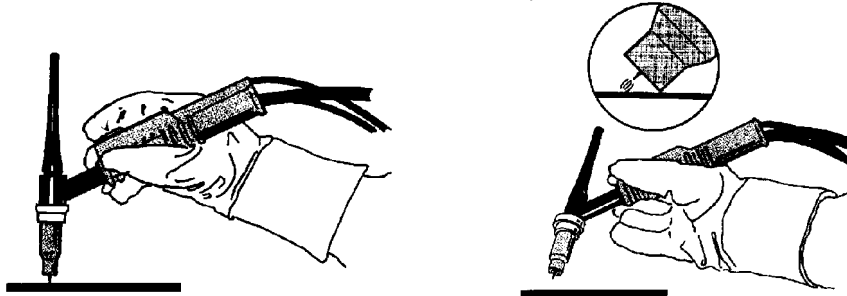

## 6.7 Remote control unit

The remote control unit is connected to the remote control socket on the power source.

---

# 7 MAINTENANCE

---

*Regular maintenance is important for safe, reliable operation.*

*Only those persons who have appropriate electrical knowledge (authorized personnel) may remove the safety plates to connect or carry out service, maintenance or repair work on welding equipment.*



### CAUTION!

*All guarantee undertakings from the supplier cease to apply if the customer himself attempts any work in the product during the guarantee period in order to rectify any faults.*

## 7.1 Inspection and cleaning

### Power source

Check regularly that the welding power source is not clogged with dirt.

How often and which cleaning methods apply depend on: the welding process, arc times, placement, and the surrounding environment. It is normally sufficient to blow down the power source with dry compressed air (reduced pressure) once a year.

Clogged or blocked air inlets and outlets otherwise result in overheating.

### TIG torch

The TIG torch's wear parts should be cleaned and replaced at regular intervals in order to achieve trouble-free welding.

## 8 FAULT-TRACING

*Try these recommended checks and inspections before sending for an authorized service technician.*

Type of fault	Corrective action
No arc.	<ul style="list-style-type: none"> <li>S Check that the mains power supply switch is turned on.</li> <li>S Check that the welding current supply and return cables are correctly connected.</li> <li>S Check that the correct current value is set.</li> <li>S Check to see whether the MCB has tripped.</li> </ul>
The welding current is interrupted during welding.	<ul style="list-style-type: none"> <li>S Check whether the thermal cut-outs have tripped (indicated by the orange lamp on the front panel).</li> <li>S Check the mains power supply fuses.</li> </ul>
The thermal cut-out trips frequently.	<ul style="list-style-type: none"> <li>S Check to see whether the dust filter is clogged.</li> <li>S Make sure that you are not exceeding the rated data for the power source (i.e. that the unit is not being overloaded).</li> </ul>
Poor welding performance.	<ul style="list-style-type: none"> <li>S Check that the welding current supply and return cables are correctly connected.</li> <li>S Check that the correct current value is set.</li> <li>S Check that the correct electrodes are being used.</li> <li>S Check the gas flow.</li> </ul>

### 8.1 Fault codes

Tradesarc 200 comes with built-in fault monitoring. If a fault occurs, a code is shown in the display, see page 15.

## 9 CONTROL PANEL



When mains power is supplied the unit runs a self diagnosis of the LEDs and the display, the program version is displayed and in this example the program version is 0.18.





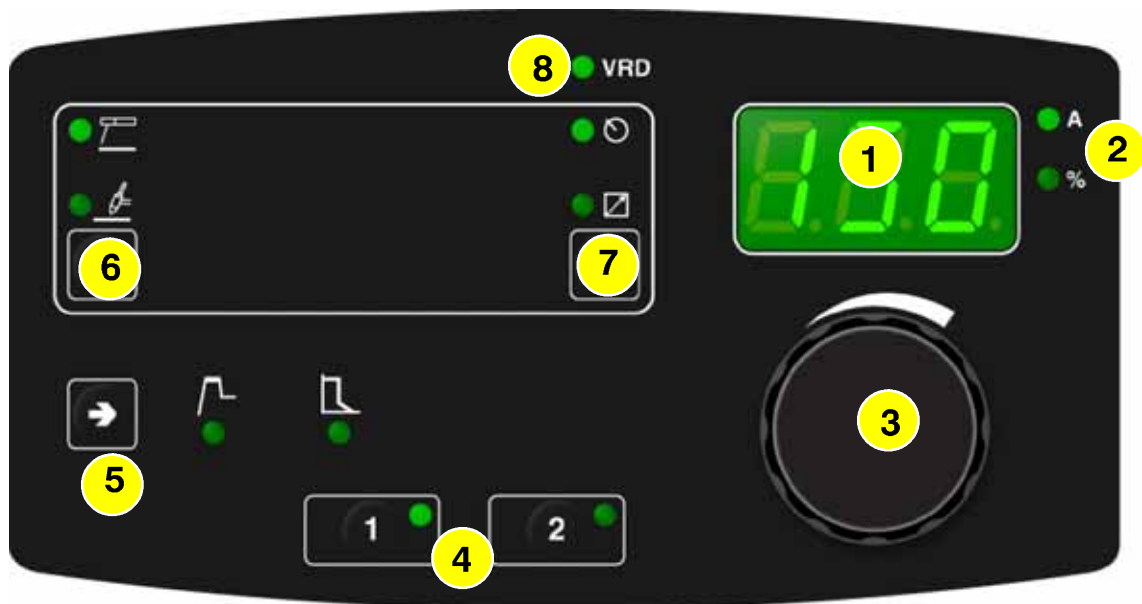

### VRD (Voltage Reduction Device)

The VRD function ensures that the open-circuit voltage does not exceed 35 V when welding is not being carried out. This is indicated by a lit VRD LED. The VRD function is deactivated when the system senses that welding has started.

If the VRD function is activated and open-circuit voltage exceeds the 35 V limit, this is indicated by an error message (16) appearing in the display and welding cannot be started whilst the error message is displayed.

**NOTE!** *The VRD function is not active (LED has gone out) on delivery. Contact an authorised ESAB service technician to activate the function.*



- 1 Display
- 2 Indication of which parameter is shown in the display (current or percent)
- 3 Knob for setting data (current or percent)
- 4 Buttons for weld data memory settings. See title 12.
- 5 Button for choosing parameters "Hot start"  or arc pressure "Arc force"  when MMA welding
- 6 Choice of welding method MMA  or TIG 
- 7 Setting from panel  and connecting remote control unit 
- 8 Display of VRD function (reduced open-circuit voltage).

---

## 10 MMA WELDING

---

### 10.1 Settings

Function	Setting range	Tradesarc 200
Current	4 max <sup>1)</sup>	x
Active panel	OFF or ON	x
Remote control unit	OFF or ON	x
Hot start	0 - 99%	x
Arc force	0 - 99%	x
Drop welding	OFF or ON	x <sup>2)</sup>
VRD	-	-

<sup>1)</sup> The setting range is dependent on the power source used.

<sup>2)</sup> Hidden function

### 10.2 Symbol and Function explanations



#### MMA welding

MMA welding may also be referred to as welding with coated electrodes. Striking the arc melts the electrode, and its coating forms protective slag.

#### Setting current

A higher current produces a wider weld pool, with better penetration into the workpiece.



#### Active panel

Settings are made from the control panel.



#### Remote control unit

Settings are made from the remote control unit.

The remote control unit must be connected to the remote control unit socket on the machine before activation. When the remote control unit is activated the panel is inactive.



#### Hot Start

Increases the welding current during a fixed time at the start of the welding process. Set the value of the hot start current by using the knob. This reduces the risk of incomplete fusion at the start of the weld.



#### Arc force

The arc force is important in determining how the current changes in response to a change in the arc length. A lower value gives a calmer arc with less spatter.

## 10.3 Hidden functions MMA welding

There are hidden functions in the control panel.

To access the functions in Tradesarc 200, hold button  depressed for 5 seconds. The display shows a letter and a value. The correct function is selected by pressing the buttons. The knob is used to change the value of the selected function.

Function letter	Function
C	Arc Force
H	Hotstart
d	Drop welding

To leave the function in Tradesarc 200 hold the button  depressed for 5 seconds.

### Arc force

The arc force is important in determining how the current changes in response to a change in the arc length. A lower value gives a calmer arc with less spatter.

### Hot Start

Increases the welding current during a fixed time at the start of the welding process. Set the value of the hot start current by using the knob. This reduces the risk of binding defects at the start of the weld.

### Drop welding

Drop welding can be used when welding with stainless electrodes. The function involves alternately striking and extinguishing the arc in order to achieve better control of the supply of heat. The electrode needs only to be raised slightly to extinguish the arc.

---

## 11 TIG WELDING

---

### 11.1 Settings

Function	Setting range	Tradesarc 200
Current	4 max <sup>1)</sup>	x
Active panel	OFF or ON	x
Remote control unit	OFF or ON	x
VRD	-	-

<sup>1)</sup> The setting range is dependent on the power source used.

## 11.2 Symbol and Function explanations



### TIG welding

TIG welding melts the metal of the workpiece, using an arc struck from a tungsten electrode, which does not melt itself. The weld pool and the electrode are protected by shielding gas.

#### "LiveTig start"

With "LiveTig start" the arc strikes when the tungsten electrode is brought into contact with the workpiece and then lifted away from it.

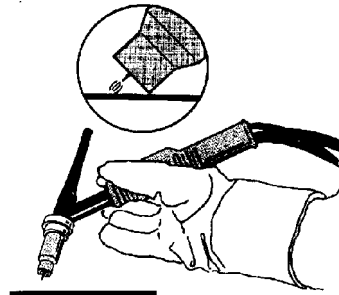
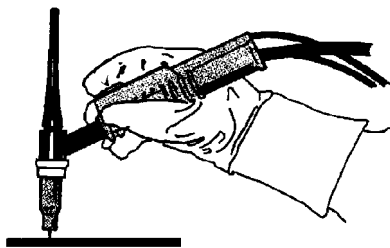

### Active panel

Settings are made from the control panel.



### Remote control unit

Settings are made from the remote control unit.



The remote control unit must be connected to the remote control unit socket on the machine before activation. When the remote control unit is activated the panel is inactive.



---

## 12 WELDING DATA MEMORY

---

Two different welding data programs can be stored in the control panel memory.

Press button  or  for 5 seconds to store the welding data in the memory. The welding data is stored when the green indicator lamp starts to flash.

To switch between the different welding data memories press button  or .

The welding data memory has a back-up so that the settings remain even if the machine has been switched off.

---

## 13 FAULT CODES

---

Fault codes are used to indicate that a fault has occurred in the equipment. It is indicated in the display by an E followed by a fault code number.

If several faults have been detected only the code for the last occurring fault is displayed. Press any function button or turn the knob to remove the fault indication from the display.

**NOTE!** If the remote control unit is activated, deactivate the remote control unit by pressing  to remove the fault indication.

### 13.1 Fault code descriptions

The fault codes that the user can correct themselves are given below. If a different code appears, call a service technician.

Fault code	Description
E 6	<b>High temperature</b> The thermal overload cut-out has tripped. The current welding process is stopped and cannot be restarted until the temperature has fallen. <b>Action:</b> Check that the cooling air inlets or outlets are not blocked or clogged with dirt. Check the duty cycle being used, to make sure that the equipment is not being overloaded.
E 14	<b>Communication error (bus off)</b> Serious interference on the CAN bus. <b>Action:</b> Check that there are no faulty units connected on the CAN bus. Check the cables. Send for a service technician if the fault persists.
E 16	<b>High open-circuit voltage</b> Open circuit voltage has been too high. <b>Action:</b> Turn off the mains power supply to reset the unit. Send for a service technician if the fault persists.
E 19	<b>Memory error</b> Content of existing memory is incorrect. Basic data will be used. <b>Action:</b> Turn off the mains power supply to reset the unit. Send for a service technician if the fault persists.

---

## 14 ORDERING SPARE PARTS

---

*Repair and electrical work should be performed by an authorized serviceman.  
Use only original spare and wear parts.*

Tradesarc 200 is designed and tested in accordance with the international and European standards IEC/EN 60974-1 and EN 60974-10. It is the obligation of the service unit which has carried out the service or repair work to make sure that the product still conforms to the said standard.

---

## 15 DISMANTLING AND SCRAPPING

---

Welding equipment primarily consists of steel, plastic and non-ferrous metals, and must be handled according to local environmental regulations.  
Coolant must also be handled according to local environmental regulations.

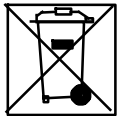

**Do not dispose of electrical equipment together with normal waste!**

In observance of European Directive 2002/96/EC on Waste Electrical and Electronic Equipment and its implementation in accordance with national law, electrical equipment that has reached the end of its life must be collected separately and returned to an environmentally compatible recycling facility. As the owner of the equipment, you should get information on approved collection systems from our local representative.

By applying this European Directive you will improve the environment and human health!



# Diagram

## Tradesarc 200

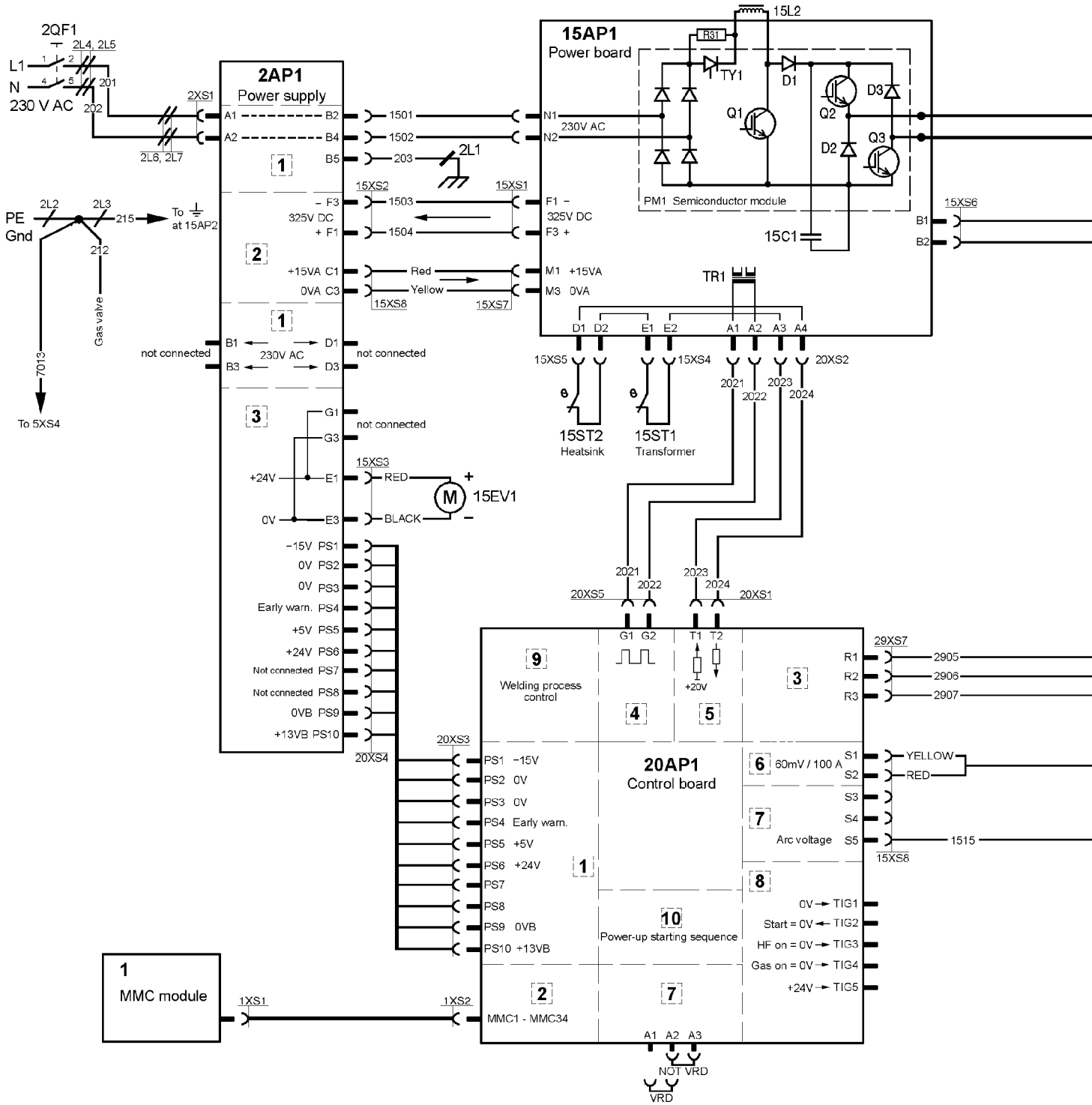

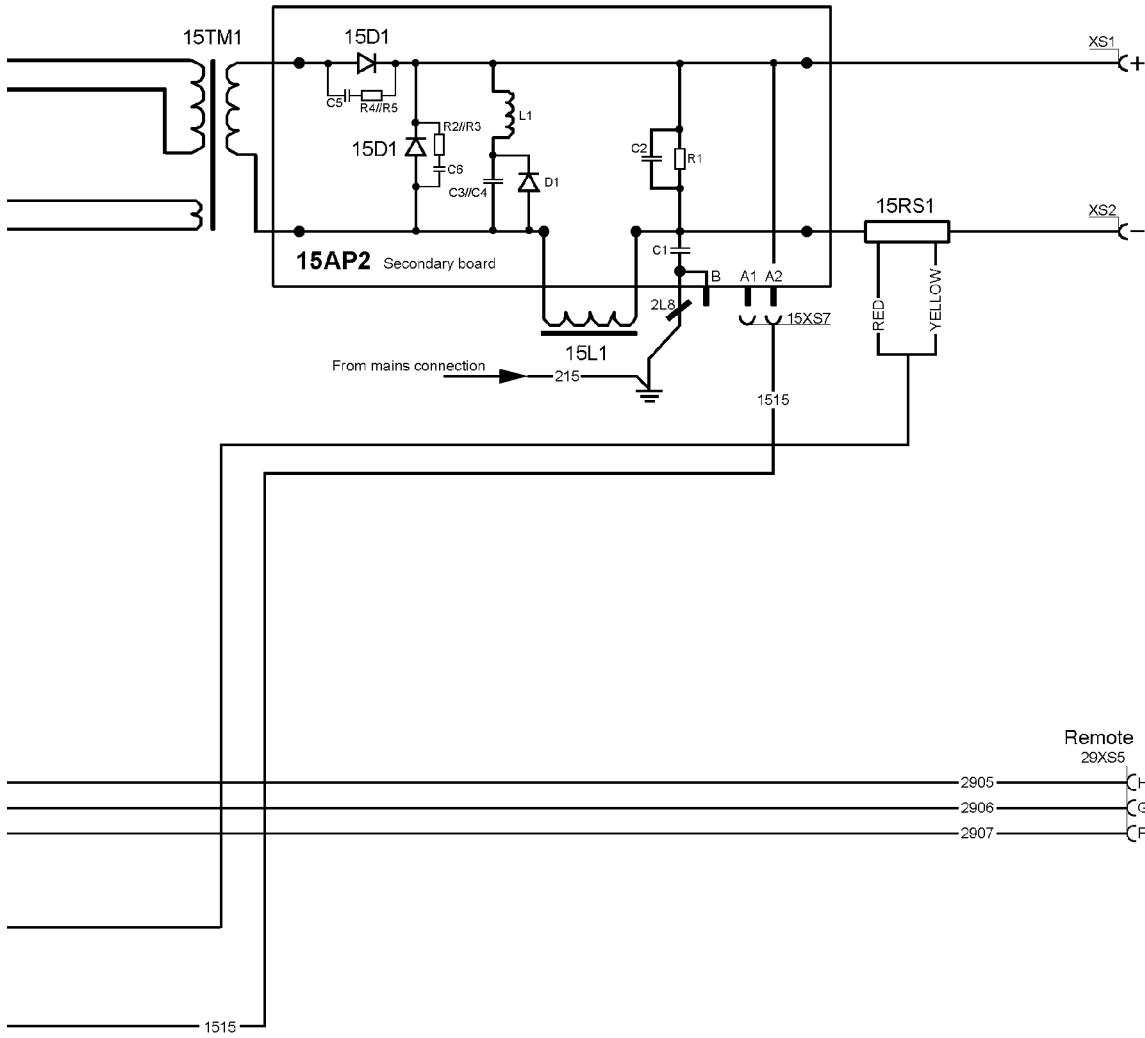



## Spare parts list

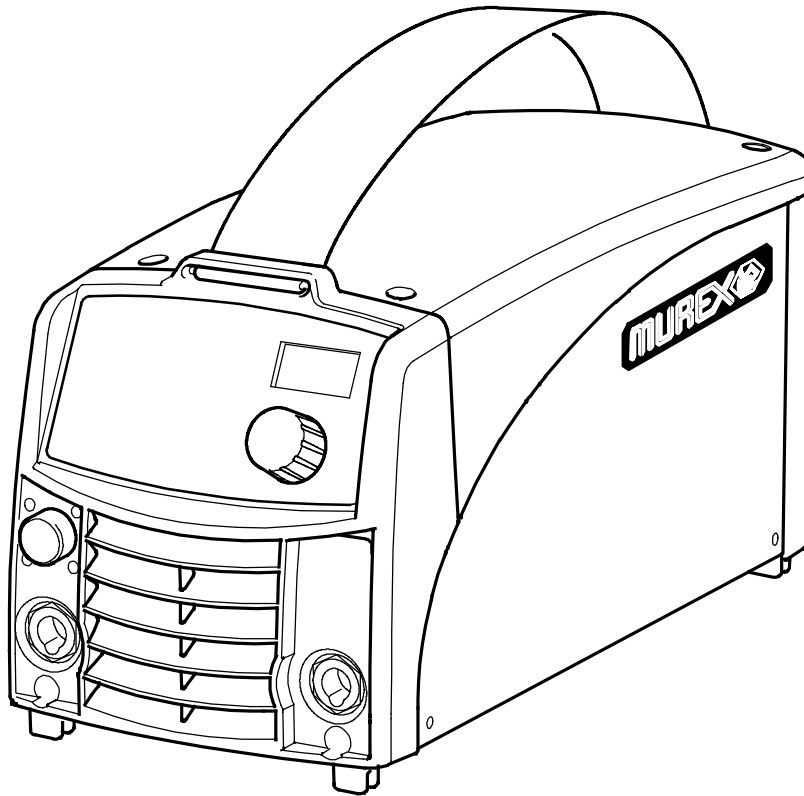

Valid for serial no. 827-xxx-xxxx

### Ordering number

0460 441 881 Tradesarc 200, 230 V 50/60 Hz with MMA-kit

Spare parts are to be ordered through the nearest MUREX agency. Kindly indicate type of unit, serial number, denominations and ordering numbers according to the spare parts list.

Maintenance and repair work should be performed by an experienced person, and electrical work only by a trained electrician. Use only recommended spare parts.

C = component designation in the circuit diagram

Item	Qty	Ordering no.	Denomination	Notes	C	
AA1	1	0193 317 001	Switch	Included in item AA50	2QF1	
AA2	1	-	Cord set	Included in item AA50		
AA3	1	0460 140 001	Rear panel			
AA4	1	0460 143 001	Cover			
AA5	1	0460 476 881	MMC Module Tradesarc 200	Control panel. Including Insulation sticker and AA6		
-	1	0460 420 001	Insulation sticker	Included in AA5		
AA6	1	0460 600 528	Knob	Included in AA5		
AA7	1	0193 700 711	Ribbon cable with connectors	34 pole		1XS1, 1XS2
AA8	1	0460 479 004	Side panel	right		
AA9	1	0460 479 003	Side panel	left		
AA10		0194 179 327	Screw MRT	ground cutter, M5x12		
AA11	1	-	Front panel	Included in item AA51	XS25, XP5	
-	1	0460 690 002	Sticker	Tradesarc 200		
AA14	5	0366 588 001	Nut			
AA15	1	0459 280 887	Cable with connector	Included in AA51		
AA16	1	0366 285 001	Protection cap	12 pole, included in AA51		
AA17	1	0460 427 001	Bar plus			
AA18	1	0460 152 981	Cable set course			
AA19	2	0366 247 001	Nut	Included in AA51		
AA20	2	0366 306 003	Spring washer	Ø21/15x1, included in AA51		
AA21	2	0160 362 025	Connector OKC 50	Included in item AA51		XS1, XS2
AA22	1	0460 265 001	Strap			
AA23	2	0468 497 001	Holder			
AA24	6	0469 381 002	Fast lock nut	M5		

**SPARE PARTS SETS**

Item	Qty	Ordering no.	Denomination	Notes
AA50	1	0460 601 880	Mains module	Includes items: AA1 switch, AA2 mains cable with plug, cable clamp and one ferrite rings 2L2.
AA51	1	0460 379 893	Front complete	Includes items: AA11, AA12, AA15, AA16, AA19, AA20, AA21 When replacing "front complete" also item AA5, MMC module, must be replaced.

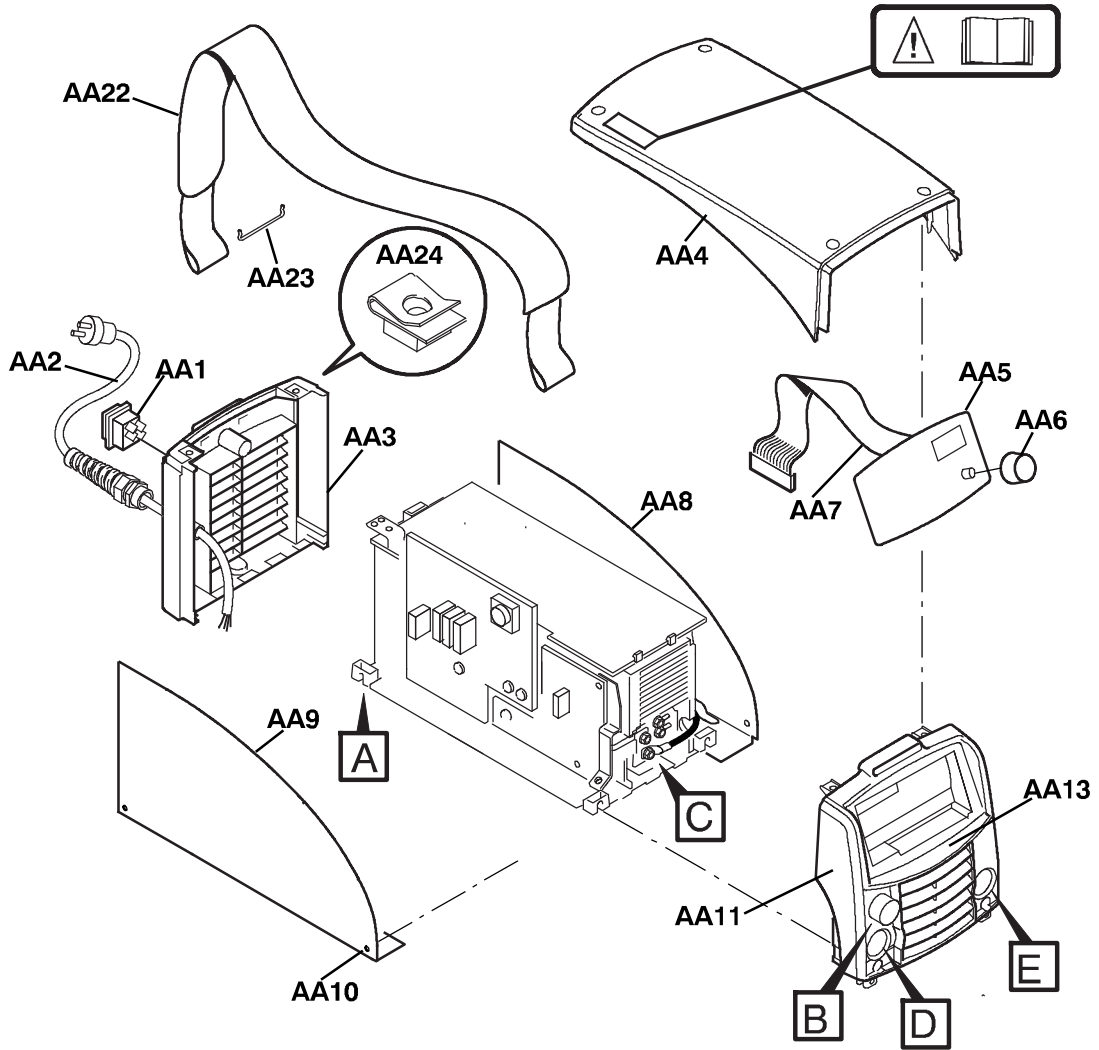

AH0888m

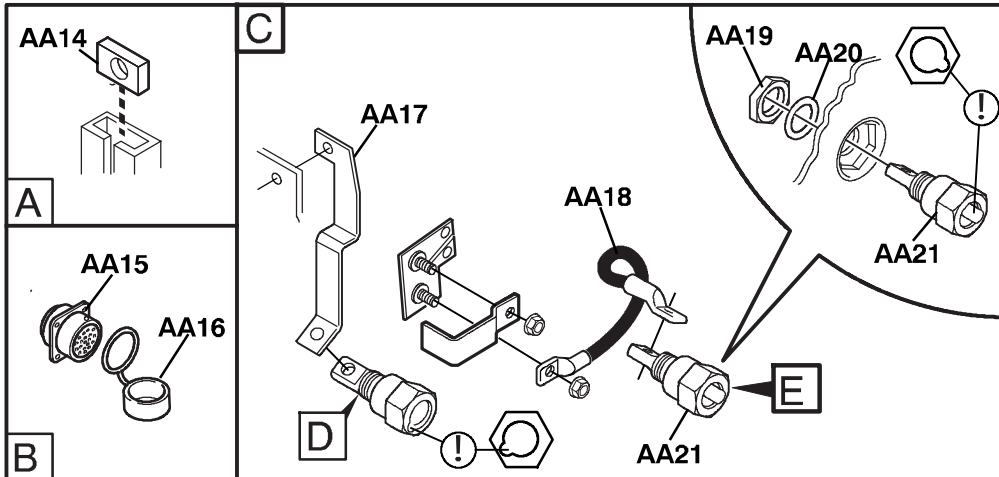

## Tradesarc 200

C = component designation in the circuit diagram

Item	Qty	Ordering no.	Denomination	Notes	C
AB1	1	0487 631 880	Power supply board	Tradesarc 200	2AP1
AB2	1	0193 700 702	Ribbon cable with connectors	10 pole	20XS3, 20XS4
AB3	1	0487 599 883	Control board	Configured for Tradesarc 200	20AP1
AB4	1	0468 940 005	Thermal switch	Socket connector 15XS5 included	15ST2
AB5	1		Diode module	See item AB50	15D1
AB6	1	0459 177 001	Inductor		15L1
AB7	1	0459 355 881	Transformer	Includes: main transformer, socket 15XS4, socket 15XS6, thermal switch 15ST1	15TM1
AB8	1	0460 117 001	Inductor	PFC	15L2
AB9	1	0194 158 003	Capacitor	1000 uF 450 V DC	15C1
AB10	1	0467 065 002	Fan	Tradesarc 200, 24V DC; With cables and socket 15xS3	15EV1
AB11	1		Circuit board	See item AB51	15AP1
AB12	1		Semiconductor module	See item AB51	
AB13	1	0468 030 880	Shunt		15RS1
AB14	1	0459 194 001	Busbar		
AB15	1	0487 060 880	Secondary board		15AP2

### SPARE PARTS SETS

Item	Qty 201i	Ordering no.	Denomination	Notes
AB50	1	0459 385 881	Diode module kit	Includes: item AB5 diode module, screws (type A and B), thermal compound and roller.
AB51	1	0459 384 884	Power board kit	Includes: item AB11 power board, item AB12 semiconductor module, screws (type A and B), thermal compound and roller.
-		0458 910 002	Roller handle	For the roller in the spare parts sets above
-		0192 058 101	Thermal compound	

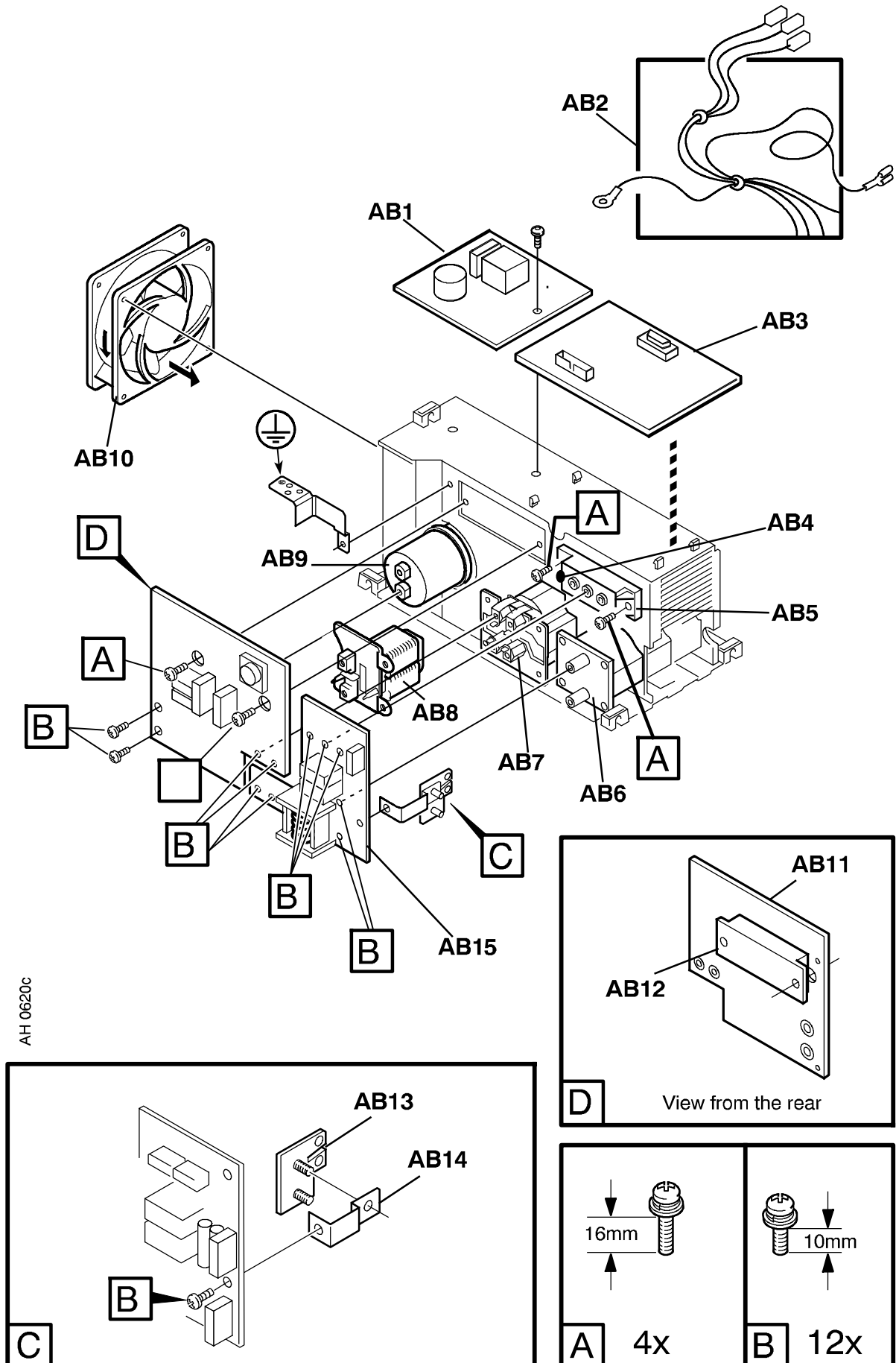



AH 0620C

# Tradesarc 200

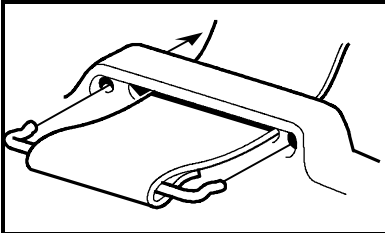
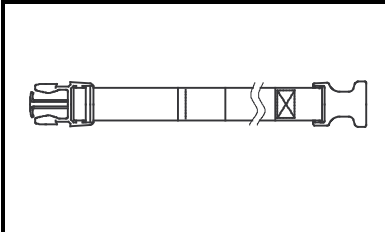
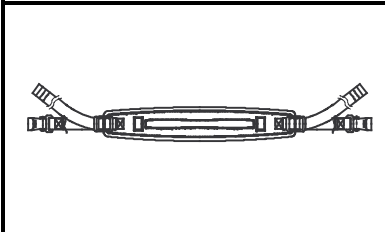
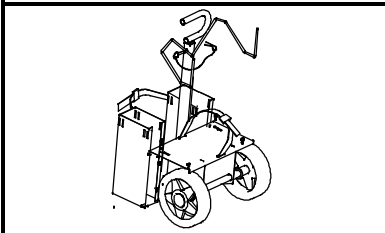
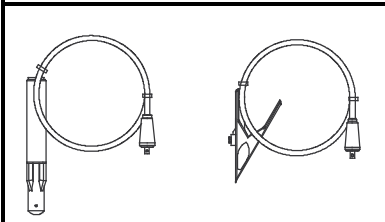
## Accessories

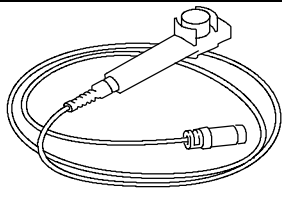
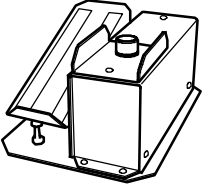
	<p><b>Strap</b> ..... 0460 265 001</p>
	<p><b>Cable holder 2 pcs</b> ..... 0460 265 002</p>
	<p><b>Shoulder strap</b> ..... 0460 265 003</p>
	<p><b>Trolley</b> for 5-10 litre gasbottle ..... 0459 366 885</p>
	<p><b>Welding cable kit, Tradesarc 200</b> ..... 0700 006 900 <b>Return cable kit, Tradesarc 200</b> ..... 0700 006 901</p>

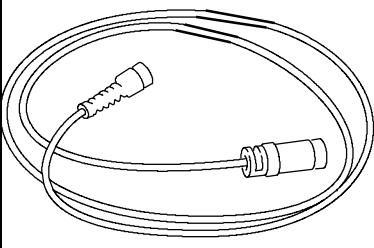
	<p><b>Remote control MMA 1 (10 m cable)</b> ..... 0349 501 024 MMA and TIG: current</p>
	<p><b>Foot control FS002</b> ..... 0349 090 886 MMA and TIG current</p>
	<p><b>Remote control unit AT1</b> ..... 0459 491 896 MMA and TIG: current</p>
	<p><b>Remote control unit AT1 CF</b> ..... 0459 491 897 MMA and TIG: rough and fine setting of current.</p>
	<p><b>Remote cable 12 pole - 8 pole</b></p> <p>5 m ..... 0459 552 880 10 m ..... 0459 552 881 15 m ..... 0459 552 882 25 m ..... 0459 552 883</p>



**Please ensure that this  
Operating Manual is  
available to the user of  
the equipment.**



Murex Welding Products Ltd  
Hanover House  
Queensgate  
Britannia Road  
Waltham Cross  
Hertfordshire EN8 7TF  
England

