



SERVICE NOTES

Tradestig AC/DC 161i

16.05.00

SERVICE NOTES

Tradestig AC/DC 161i

General

The 161i consists of 4 PCB assemblies interconnected mainly by ribbon cables:

- 1. INVSS PCB (PCB 1)**

The main dc inverter. 230V mains is rectified and smoothed giving a 320V dc line voltage. Note the "soft start" resistor and relay bypass network. This is then switched at high frequency (50KHz approx) by two banks of MOSFET's (5 per bank) and fed to the ferrite cored main transformer (also mounted on the PCB ass'y). A small current transformer, in series with the main transformer primary, provides a signal to the feedback control. The secondary rectifier ass'y is also mounted on this PCB together with the output choke. A thermal switch mounted on the rectifier heatsink provides overduty protection.
- 2. SSACINV PCB (PCB 2)**

Comprises four banks of MOSFET's arranged in a bridge network (3 each on the vertical AC +ve arms, and 4 each on horizontal AC & DC -ve arms). Drive signals from the logic control PCB drive the MOSFET's to provide either dc or ac output to the welding terminals. **Note the ac frequency is not locked to 50Hz but varies inversely with welding current** setting over the range 40-200Hz approx. When AC TIG mode is selected the arc is struck with the electrode DC +ve w.r.t. the work. After a short period, around 0.5 secs, the commutator starts to switch backwards & forwards.
- 3. SSHFAC PCB (PCB 3)**

Generates "HF" spikes under command from the logic control PCB. It is supplied direct from the 230V mains supply and develops 600V spikes which are fed to coupling transformer T1 in the welding output circuit. The HF discharge repetition rate is linked to the welding current setting along with the AC frequency, see above. Also a relay (RL2) on this PCB changes the polarity of the HF pulse to match the differing requirements of DC and AC TIG welding modes. This PCB also drives the gas solenoid valve EV1 via relay RL1 on this PCB.
- 4. SSACDC PCB (PCB 4)**

The main control and logic PCB for the 161i. Incorporates front panel switches and controls and is the connection point for the torch switch and remote control sockets etc.

CHECKING THE UNIT

1. If the unit is operating correctly the following OCV values should be present at the dins terminals:

- a) Unit idling, 2 stroke TIG mode, torch switch not pressed

OCV	AC mode	+ 15 ± 5Vdc	(w.r.t. the +ve/work socket)
	DC mode	- 15 ± 5Vdc	(w.r.t. the +ve/work socket)

Note this is a "leakage" voltage with no current supply capability

- b) Unit in MMA mode, but not welding

OCV	AC mode	+ 50 ± 3Vdc	(w.r.t. the +ve/work socket)
	DC mode	- 50 ± 3Vdc	(w.r.t. the +ve/work socket)

The change of output polarity when the switch is changed from AC to DC is a clear indication the com. PCB is operating correctly. Also the presence of 50V OCV in MMA mode indicates both the com. PCB2 and the main inverter PCB1 are working. However, no output **does not mean that both** the com. and the main inverter PCBs are defective!

2. The main inverter PCB1 can be readily checked as follows:

- a) Disconnect at the com. PCB the 2 white high current leads that connect the main inverter PCB output to the com. PCB.
- b) Disconnect the ribbon cable that connects the main inverter PCB1 to the logic/control PCB4.
- c) Measure the voltage between the 2 white high current output leads from the main inverter pcb (previously disconnected from the com.) This should be 90-100Vdc.
- d) If like this there is no output from the main inverter PCB check for 240V ac input to it at its input terminals (upper right hand corner). If 240V is present then replace the main inverter PCB1. **Note this may not be the only defect in the machine!**

3. Assuming the tests in 2. above indicate the main inverter PCB1 is working and there is still no output from the unit per test 1. then the com. PCB and/or the front panel logic/control PCB may be defective. Testing these is more difficult.

In addition, if the tests in 2. above indicate the main inverter PCB is defective (no output) then finding other possible faults in the logic/control PCB and/or com. PCB is more complex still depending on whether or not the +24Vdc unregulated supply developed on the main inverter PCB is still present.

4. a) Irrespective of whether or not the main inverter PCB has passed or failed per 2. above, switch off and reconnect its ribbon cable that runs to the logic/control PCB. Note leave the white high current output leads disconnected from the com. PCB. Disconnect the ribbon cable between the logic/control PCB and the com. PCB. With the unit idling measure the unregulated +24Vdc supply voltage on the control/logic PCB between the upper of the 2 unused ¼" push on connections (A2) on the LH edge of the PCB (viewed from the component side/rear of machine) which is 0v, and the cathode of D1a which is located immediately above the AC/DC polarity switch in horizontal fashion, see sketch attached.
- b) If +24Vdc is present (note this supply is generated on the main inverter PCB) then carryout the following to confirm the logic/control PCB is OK.
- Check when the AC/DC selector switch is operated that relay RL2 on the HF/GV PCB operates.
 - Check when the torch switch is pressed in the 2S mode relay RL1 on the HF/GV PCB operates and the gas valve pulls in. Check also that the valve and relay remain energised after the torch switch is released until the post flow timer has timed out.
 - Measure the voltage at wiper "B" of the AC/DC selector switch on the logic/control PCB with respect to 0v, see 4a) above. When DC is selected this should be +12Vdc. When AC is selected this should be <0.5Vdc, note this latter value should vary with the setting of the AC balance control **reducing as the balance control is turned clockwise.**
 - Check when the torch switch is pressed in 2S 'HF' mode that the HF generator runs - it should be audible and the frequency of it should vary with the main current & start current settings.
 - If all these tests are OK then the logic/control PCB is good.
- c) If +24Vdc is not present then you must assume **both** the main inverter PCB1 and the logic/control PCB4 are defective or the ribbon cable between them is faulty as it is not possible to check the logic/control PCB without this supply.

5. Testing the AC/DC com. PCB2

- a) Disconnect the 2 "white" input cables from the main inverter PCB. Disconnect the ribbon cable connection to the logic/control PCB. With an ohmmeter (preferably an old fashioned AVO type on ohms x 100) and referring to the schematic circuit diagram check across the main current input and output brass connection studs. If the MOSFETS are not short or open circuit measurements should show either forward biased diode resistance or open circuit depending on which way round the meter is connected. Note a diagonal measurement bottom right to top left stud should show the effect of 2 diode resistances if the bottom right is made +ve (black lead) and be open circuit if the top left is the +ve.
- b) If the main PCB1 and logic/control PCB4 test out OK per 2,3 & 4 above and test 5a) is OK but the unit still does not work per 1. replace the com. PCB2.

6. Testing the HF/GV PCB3

- a) With the unit idling in 2S 'HF' mode check that RL1 (changing the HF polarity) operates as the AC/DC polarity switch is operated. Check that RL2, operating the gas valve, pulls in when the torch switch is pressed and holds for the post gas purge time. Check that 240Vac is present at its input terminals, the front right hand pair.
- b) Using a meter check for 620Vdc as shown in the HF/GV PCB layout attached (SSHFAC). Note this is "live" to mains so be careful! (If the voltage is low or not present replace PCB 3).
- c) If the gas valve relay RL2 does not operate when the torch switch is pressed check between Ov (see 4a) above) and the RHS (from machine front) of resistor R1 with a voltmeter. This should be +10V to energise the relay. If there is no voltage here suspect the logic/control PCB or ribbon cable. (If the voltage is present replace PCB 3).
- d) If the HF polarity relay RL1 does not operate when the front panel AC/DC polarity switch is operated check between Ov and the anode of D5. This should be +24V in DC and Ov in AC. If not again suspect the logic/control PCB rather than the HF/GV PCB and check also the ribbon cable. (If the voltage is present replace PCB 3).
- e) To check the HF firing pulses from the logic/control PCB to the HF/GV PCB measure from Ov (see above) to front of R10 (from machine front) on the HF/GV PCB. Press the torch switch (2S 'HF' mode) and a reading of 0.2-0.33V should be obtained depending on the main current/start current settings. If not suspect the logic/control PCB.

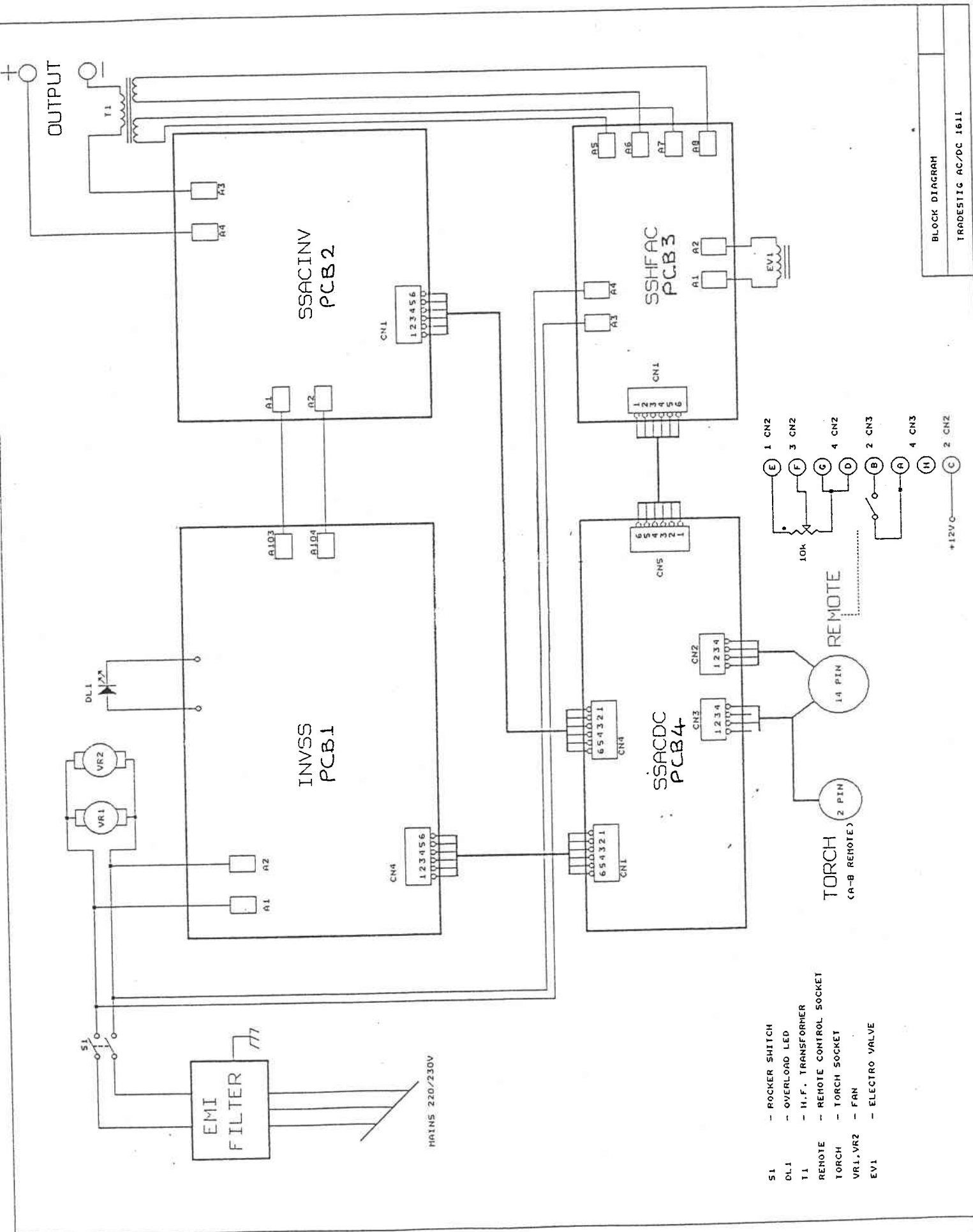

- S1 - ROCKER SWITCH
- DL1 - OVERLOAD LED
- T1 - H.F. TRANSFORMER
- REMOTE - REMOTE CONTROL SOCKET
- TORCH - TORCH SOCKET
- VR1, VR2 - FAN
- EV1 - ELECTRO VALVE

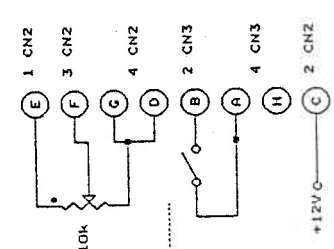

BLOCK DIAGRAM
TRADESTIG AC/DC 1611